

TOYO **ED** MOTOR

INSTRUCTION MANUAL

Permanent magnet type synchronous motor

EDM Series

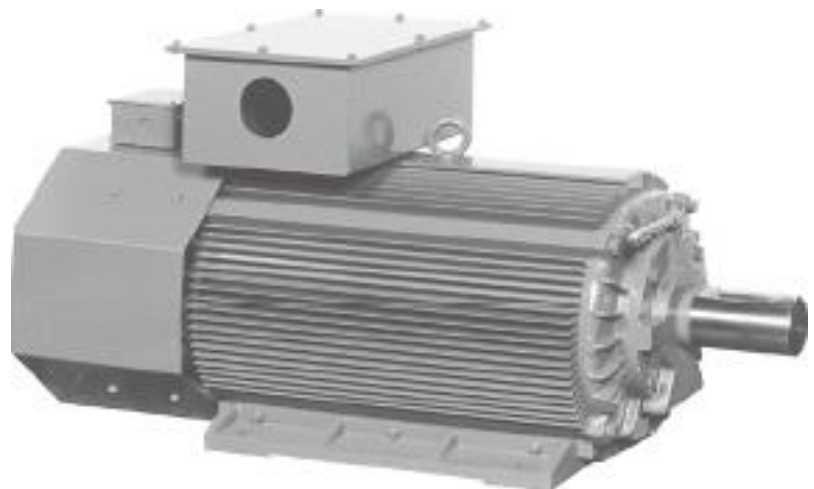

CONTENTS

Please read surely the following precautions

I. Preparation for operation	-----1
1. Checking at arrival of motor	-----1
2. Installation	-----1
3. Electric wiring	-----5
II. Trial operation and ordinary operation	-----7
1. Before powering	-----7
2. After powering	-----7
III. Maintenance, checking	-----8
1. Daily checking	-----8
2. Periodical checking	-----8
3. Bearing and lubrication	-----8
4. Checking of accessories	-----10
5. Service life of main accessory parts	-----10
IV. Preparation for operation	-----11
1. Storage	-----11
V. Disassembly, Assembly	-----12
1. Procedures of disassembly and assembly	-----12
2. Replacement of bearing	-----16
3. Structural drawing of motor	-----17
VI. Troubleshooting of motor	-----19
VII. Industrial Product Warranty	-----21

Please read surely the following precautions

Introduction

We thank you for your adoption of Toyo Denki ED Motor (permanent magnet type synchronous motor). This Manual shows handling method of ED motor and precautions on use for customers having general knowledge on permanent magnet type synchronous motor. Before use, please read this Manual carefully until getting of enough knowledge on our ED motor and use it when it is in optimum condition. After reading, please keep this Manual close to the place where ED motor is used. In case of lease or transfer of ED motor, deliver this Manual together. When ED motor is used combining with machine or equipment, please arrange this Manual to be handed to the end user surely. If this Manual is lost or damaged, please order new one from us or our distributor. Meanwhile there is a possibility that we change parts of ED motor for the purpose of improvement of quality/performance or for safety. At such time, there may be a case that a part of content and illustration, etc. of this Manual does not conform to the original parts, for which please understand. If there are any points which are unclear, please consult us or our distributor.

Safety precautions

Before works of installation, operation, maintenance, inspection, etc., please read carefully this Manual and the manual of Inverter equipment (VF66B, etc.) and all of other attached documents surely for correct use. Please use ED motor after getting enough knowledge on it as well as information on safety and all precautions. After reading, keep this Manual close to the place where operator can read it easily at anytime. In this Manual, ranking of safety precautions is classified to [Danger] and [Caution].

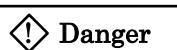

Danger

: In case of error in operation, dangerous situation may occur and it could result in death or serious injury.

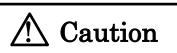

Caution

: In case of error in operation, dangerous situation may occur and it could result in medium or light injury, or damage to physical property only.

Even in case of above  **Caution**, there is a possibility to lead to serious result depending on the situation.

Since important contents are written in both safety precautions, make sure to observe them.

Danger

(General)

- Works of transportation, installation, piping, wiring, operation, maintenance, inspection must be carried out by qualified expert. Otherwise, that could result in electric shock, injury, fire, etc.
- Avoid the work in state of hot-line. Be sure to work after breaking of power supply. Otherwise, that could result in electric shock.
- Even in state that power supply is interrupted, voltage is generated at motor terminal while motor is running. Do not touch the motor until perfect stop of rotor and also avoid the work. Otherwise, that could result in electric shock and injury.
- In state that the power supply is interrupted, do not apply the motor to the usage which has a possibility of being rotated faster than motor rating speed by the load. Otherwise, that could result in burning and fire.
- Never use the motor in explosive atmosphere. Otherwise, that could result in injury, fire, etc.

(Installation)

- Surely ground the terminal for earthing. That could result in electric shock.
- In case of use of motor fitting on the ceiling or on the wall, it may drop depending on the conditions. Therefore, please obey to catalog and technical materials in regard to the details of range of use. Otherwise, that could result in injury.
- Operate the motor after confirmation that protection devices are firmly connected and they activate normally. Otherwise, that could result in injury and fire.

 **Danger**

- Do not operate the motor in state that the cover of terminal box is removed. After work, fit the cover of terminal box at the original position. Otherwise, that could result in electric shock.

(Piping, wiring)

- Connection with power supply cable should be done in accordance with connection diagram or Instruction Manual. Erroneous wiring could result in electric shock and fire.
- Do not bend or pull or put between something the power supply cable and lead wire of motor forcibly. Otherwise, that could result in electric shock.

(Operation)

- Never approach to or contact the rotating objects (shaft, etc.) during operation. Otherwise, that could result in injury by being caught.
- When power is interrupted, turn off the power supply surely. Otherwise, that could result in injury when power is supplied again.

(Maintenance and inspection)

- Connection with power supply cable should be done in accordance with connection diagram or Instruction Manual. Erroneous connection could result in electric shock and fire.

 **Caution**

(General)

- For installation place of motor, secure safe and adequate space for maintenance and inspection. Otherwise, trouble of electric shock and injury could occur.
- Do not use the motor under out of specifications of that motor. Otherwise, that could result in electric shock, injury, breakage, etc.
- Do not insert finger or object into the aperture of motor. Otherwise, that could result in electric shock, injury, fire, etc.
- Do not use damaged motor. Otherwise, that could result in injury, fire, etc.
- In case of work at high place, prepare enough measures for prevention of drop. Otherwise, trouble of injury by drop could occur.
- Since remodeling by user is out of range of our guarantee, we are not responsible for it.
- Do not put obstacles in front of motor name plate in order for operator to see it at any time.
- Do not remove the name plate.

(Transportation)

- Since drop and falling down of the product during transportation is dangerous, please pay enough attention for such work. As to motor, surely use designated position for hanging. After installation of motor combined with machine, do not hang whole set of motor-machine at the position for hanging of motor only. Before hanging, confirm mass of motor by name plate, packing case, outline drawing, catalog, etc. and do not hang the heavier motor than the rated load of hanger. Breakage of hanger and consequent drop as well as falling down could result in breakage of motor and injury.

(Unpacking)

- Unpack the case after confirmation of top and bottom. Otherwise, that could result in injury.
- Confirm whether reached product is just the ordered one. Installation of erroneously delivered product could result in injury, breakage, etc.

(Installation, adjustment)

- Never place any inflammable objects around the motor. Otherwise, that could result in fire.
- Do not place any objects which prevent ventilation, around the motor. Otherwise, that could result in burn and fire by extraordinary overheat caused by prevention of cooling
- When motor is connected with machine, pay attention on centering, belt-setting, parallel degree of pulley, etc. In case of series connection, pay attention on direct-connection accuracy. In case of belt connection, adjust tensile strength of belt correctly. Before operation, tighten clamp bolts of pulley and coupling firmly. Otherwise, trouble of injury and breakage of equipment caused by scattering of fragments could occur.
- Avoiding touch with rotating part, mount the cover, etc. Otherwise, that could result in injury.

 **Caution**

- In case of rotating of motor alone, remove temporarily fixed key to the main shaft. Otherwise, that could result in injury.
- Before connection of motor with machine, confirm its direction of rotation. Otherwise, that could result in injury and breakage of equipment.
- Never get on and dangle from motor. Otherwise, that could result in injury.
- Do not touch with bare hand the keyway at shaft end of motor. Otherwise, that could result in injury.

(Piping, wiring)

- At the time of measurement of insulation resistance, do not touch the terminals. Otherwise, that could result in electric shock.
- Carry out wiring work in accordance with [Electrical Facilities Technical Standards] and [Inner Wiring Regulations]. Otherwise, that could result in fire.

(Operation)

- Since motor gets very hot during operation, do not touch it with hand or body. Otherwise, that could result in burn.
- When error occurred, stop operation immediately. Otherwise, that could result in electric shock, injury, fire, etc.

(Maintenance, inspection)

- At the time of measurement of insulation resistance, do not touch the terminal. Otherwise, that could result in electric shock.
- At the time of injection/discharge of grease to/from bearing, do not touch rotating object. Otherwise, that could result in injury.
- Since frame of motor gets very hot, pay attention at the time of maintenance and inspection in order to avoid burn.

(Repair, disassembly)

- Repair and disassembly should be done by qualified expert. Otherwise, electric shock, injury, fire, etc. could occur.

EDM Series ED motor is the most suitably designed motor for Inverter drive by Toyo Denki having high level technology in rotary machine and control equipment.

Explanation of type name

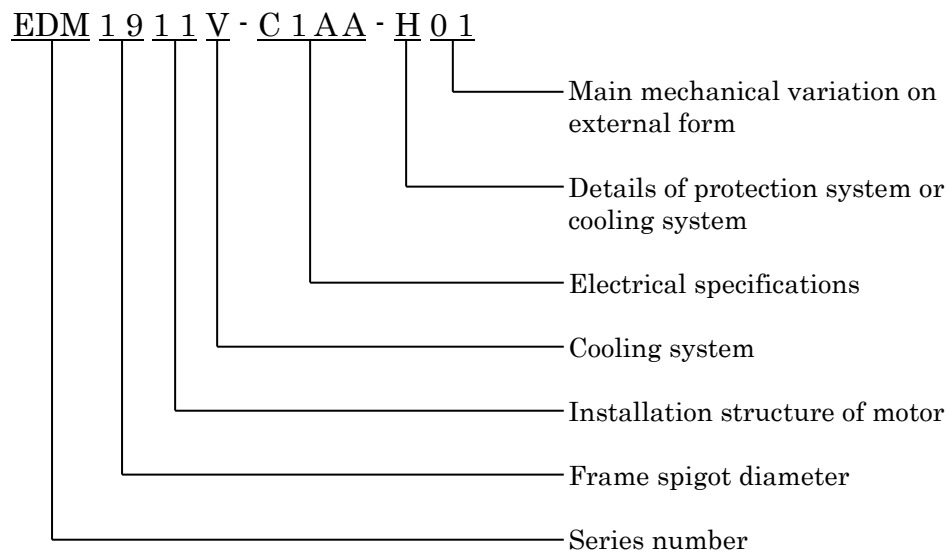

Fig. 1

I. Preparation for operation

1. Checking at arrival of motor

When the ordered motor arrived, please check paying attention to the following points.

- (1) Check the motor with our invoice separately sent.
- (2) Check the motor for damage, rusting, dropping of accessories, etc.
- (3) There is a case that the rotor of motor is fixed in order to prevent the bearing from being damaged during transportation. Check the rotor and remove it.
- (4) Rotate the shaft end manually to confirm smooth rotation.
- (5) Check the motor output, voltage, current, frequency, rotation speed, etc. shown on the name plate.

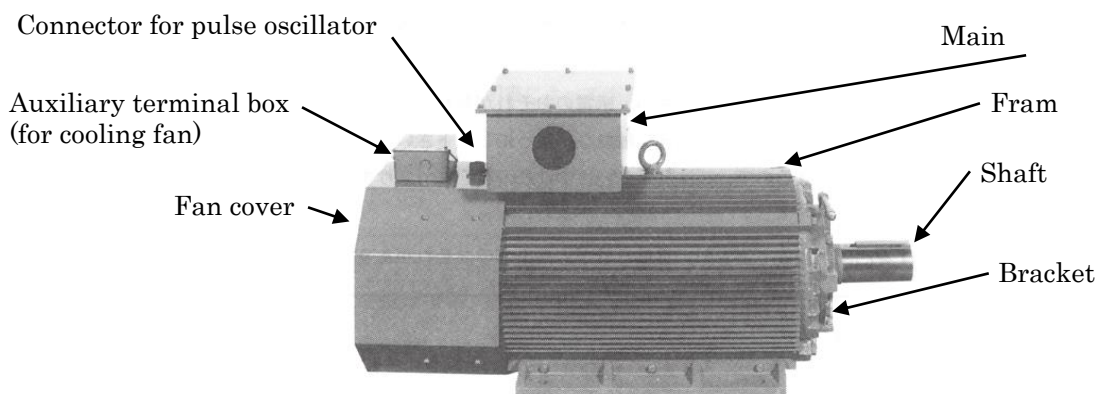

Photo. of external appearance of motor

2. Installation

2.1 Installation place

- (1) Install the motor at a well-ventilated place and arrange not to return the coming out heat from the motor, to the intake side by circulation. At a place where the ambient temperature is high or when the motor is influenced by heat radiation/conduction, take measures such as heat insulation, reduction of load, etc.
- (2) Distance between the inlet of cooling fan of the motor and the wall should be 20cm or more for EDM13~EDM31 and 30cm or more for EDM35~EDM68.
- (3) Place with less humidity.
- (4) Place with less dust. If dust is accumulated on the fins of frame, cooling effect will be reduced causing overheating. Therefore, periodical cleaning should be done in case of dusty place.
- (5) Place where motor is not influenced by noxious gas and acid/alkaline chemicals, etc. When motor is used at a place where flammable gas exists, re-check whether selected explosion proof structure conforms to the regulations of Ministry of Economy, Trade and Industry and the Ministry of Health, Labor and Welfare.
- (6) Place where such works as disassembly, inspection, cleaning and maintenance can be carried out easily.
- (7) Install the motor on a strong foundation and rigid common base so that external vibration will not be conducted to the motor. If vibration during operation is large, bearing life will be shortened and it will cause the vibration fatigue failure of fan, rotor, etc.
- (8) Place with less fluctuation of supply voltage and less voltage drop.

2.2 Connection with counterpart machine

(1) Foundation work

In order to minimize the vibration and misalignment during operation, strong foundation is required. If foundation is incomplete, machine will vibrate and bearing life will be shortened, to which please pay attention. The most ideal foundation in order to prevent generation of vibration is a strong concrete foundation but if such concrete foundation cannot be made because of counterpart machine and relation with the place, install the motor on the steel frame with bolts firmly arranging that the motor shaft exactly level (or perpendicular for a vertical motor) surely. For the base, achieve the level degree of 0.2/1000mm or less accurately. Also, clean the surfaces of concrete foundation / steel frame and of the leg of motor for ideal installation.

(2) In case of flexible coupling

- 1) Mark the matchmarks on the outer surface of coupling.
- 2) In order to rotate the couplings together, connect couplings of the counterpart machine and of the motor by one bolt.
- 3) Fix a dial gauge firmly to outer surface of one coupling. (Fig. 2)
- 4) Move the matchmark of the coupling to the top and measure the dimension-g by clearance gauge and dimension-h by dial gauge.
- 5) Rotate the coupling and carry out same measurement as above item 4) at every 90 of quadrant positions.
- 6) Adjust using shim plates so that the difference between maximum and minimum of the measured values will be 0.03mm for both g and h. Every time the measurement for adjustment is carried out, tighten the installation part with bolt sufficiently. When dial gauge cannot be fitted for a small motor, apply the stretch to the outer surface of one coupling and measure the clearance between stretch and the other coupling.

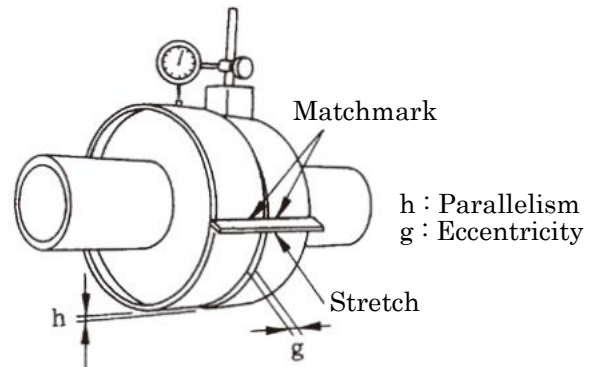

Fig. 2

(3) In case of belt drive

Set the counterpart machine shaft and motor shaft accurately parallel and apply the belt in such a way that both pulley centers coincide each other.

The belt is apt to be stretched too much however, excessive stretching will damage the bearing and cause unexpected accidents such as breakage of motor shaft, etc., to which please pay attention.

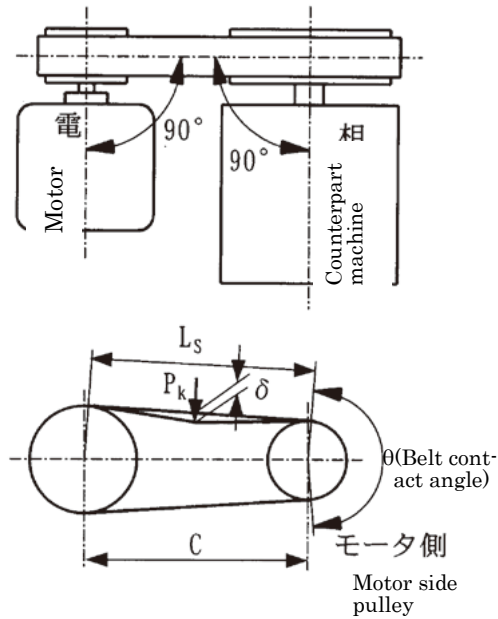

Fig. 3 Belt stretching method

1) Belt stretching method

- Step 1 : Firstly, find the belt span (Ls). Belt span is the length of the portion of belt between contact points with both pulleys.
- Step 2 : Apply the force (Pk), which is required for deflection (delta), at the center of the belt span. This required force for deflection (delta) should be calculated by the formula 5 shown below and it should be within the range of Pk1 - Pk2.
- Step 3 : Stretch the belt in such a way that the deflection (delta), when the force is applied, will be the value found by the following formula.

$$\delta = 0.016 \cdot L_s$$

2) Calculation formula

Step 1 : How to find belt contact angle (small pulley side) ... Formula 1

Formula 1

$$\theta = 180^\circ - 2 \sin^{-1} \frac{d_2 - d_1}{2C}$$

Step 2 : How to find initial tension (Fo) Formula 2

Formula 2

$$F_o = 0.9 \left\{ 500 \left(\frac{2.5 - K_\theta}{K_\theta} \right) \frac{P_d}{Z \cdot v} + m \cdot v^2 \right\}$$

Fo : Initial tension (N)

Kθ : Contact angle correction factor

Pa : Design power (kW)

Table 1

Contact angle (θ)	140°	150°	160°	170°	180°
Correction factor (Kθ)	0.89	0.92	0.95	0.98	1

$$P_d = P_N \times (K_o + K_i)$$

PN : Load power (motor output, in general) (1kW)

Ko : Load correction factor (1.0 ~ 1.5)

Ki : Idler correction factor (0 ~ 0.2)

Z : Number of belt v : Belt speed (m/sec) m : Mass/unit of belt (kg/m)

Note) Determine Ko, Ki depending on the machine to be used and operation time, referring JIS Standard or catalog, etc. of belt maker.

Step 3 : How to find span (Ls) Formula 3

Formula 3

$$L_s = \sqrt{C^2 - \frac{(d_2 - d_1)^2}{4}}$$

Ls : Span (mm)

C : Distance between shafts (mm)

d2 : Large pulley nominal diameter (mm)

d1 : Small pulley nominal diameter (mm)

Step 4 : How to find deflection (δ) Formula 4

Formula 4 $\delta = 0.016 \cdot Ls$ δ : Deflection (mm)

Step 5 : How to find necessary force (Pk1, Pk2) for deflection (δ) ... Formula 5

Formula 5

$$P_{k1}(\text{min.value}) = \frac{F_0 + Y}{16}$$

P_{k1} : Necessary force (min. value) (N) for deflection (δ)

$$P_{k2}(\text{max.value}) = \frac{1.25 \times F_0 + Y}{16}$$

P_{k2} : Necessary force (max. value) (N) for deflection (δ)

Table 2

	Kind of belt	Y(N)	m(kg/m)
Standard V belt	A type	15	0.12
	B type	20	0.20
	C type	30	0.36
	D type	60	0.66
Narrow V belt	3Vtype	20	0.08
	5Vtype	39	0.20
	8Vtype	98	0.50

Table 3

Type of motor	EDM 1711	EDM 1721	EDM 19	EDM 22	EDM 27	EDM 31	EDM 35	EDM 43
Permissible shaft load F(N)	1600	2240	2930	5360	9080	12100	18800	24200
Q (mm)	80	110	110	110	140	140	170	175
Q' (mm)	31.5	41	50.5	68	93.5	106	91.3	108.8

[Note] Type of motor, for which the belt can be applied, is till EDM4321V. EDM4331V and EDM54, EDM68 are for direct connection only.

Belt speed should be : -

- Standard V belt (A, B, C, D types) 30m/sec or less
- Narrow V belt (3V, 5V, 8V types) 40m/sec or less

This matter should be taken into consideration when pulley diameter is determined. The belt tension differs depending on the kind of belt however, the radial load imposed on the motor shaft should be less than the values in the above table.

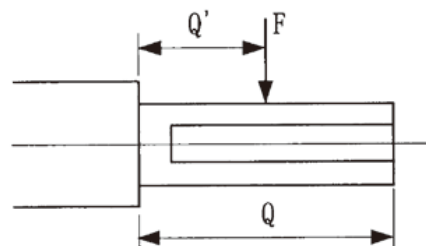

- (4) Mounting of coupling and belt pulley
 Coupling and belt pulley should be mounted carefully not to damage the motor bearing. Lightly press-fit them by wooden or plastic hammer. In case of heating, heat them until about 100°C uniformly. In case of press-fitting, remove the rust preventive agent on the shaft end by petroleum solvent or alkali solvent, and apply molybdenum disulfide.

[Caution]
 In case that the pulse oscillator for speed detection is provided on the shaft end of non-transmission side, be careful not to give impact to it when coupling and belt pulley are inserted since it may be damaged by such impact. (See Structural Drawings Fig.17~Fig.20)

- (5) In case of flange type motor flange engagement surface is accurately machined. If contaminant, paint, rust, etc. are found there, remove them surely.

3. Electric Wiring

3.1 Terminal box

There are main terminal box for motor main body terminals and thermistor, and auxiliary terminal box for electric fan. Connect external wirings correctly and firmly. Connection with pulse oscillator of motor side is connector-connection.

3.2 Connection diagram

Fig. 5 shows the standard connection diagram. In case that the temperature sensing element (pt100Ω), temperature element (bimetal type) and electromagnetic brake are provided, all these terminals are housed in the main terminal box and their terminal symbols are as shown in Fig. 6.

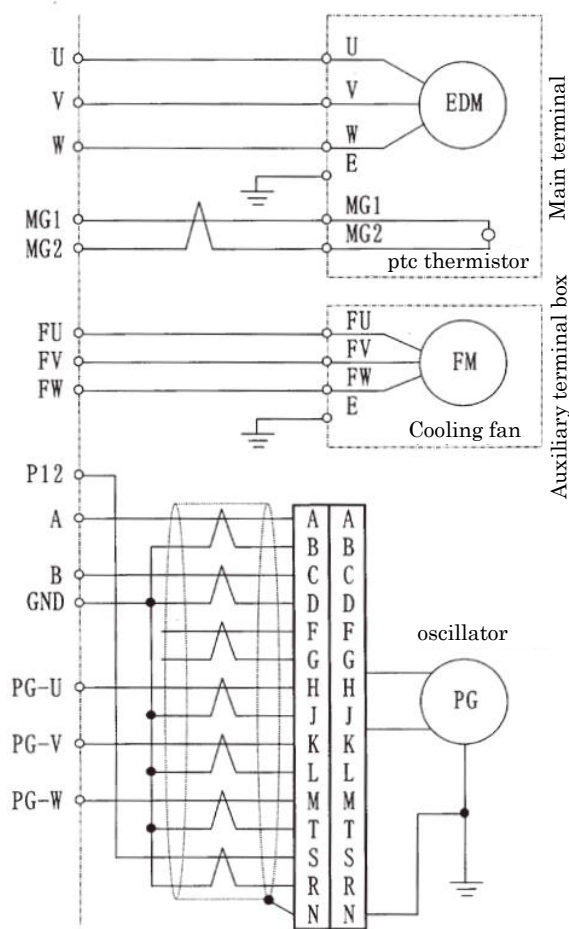

Fig. 5

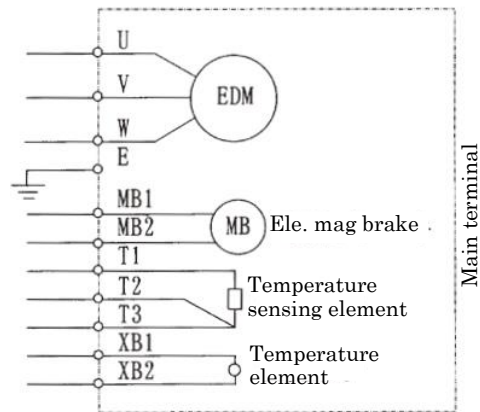

Fig. 6

Note : Cooling fan is single phase for EDM19 or less. Therefore, it has 2 terminals of FU and FV.

[Caution]

If electromagnetic brake and main power supply circuit are connected erroneously with terminals of ptc thermistor (terminals MG1, MG2), temperature sensing element (terminals T1, T2, T3) and temperature element (XB1, XB2), motor coil will be damaged caused by breakage of elements and so, enough attention should be paid. Also, do not measure insulation resistance by insulation resistance meter (Megger). If the power was turned on with wrong connection, carry out disassembly and inspection.

3.3 Direction of rotation

- (1) Direction of rotation must be correct.
- (2) Direction of rotation of the motor is expressed as seen from the shaft end of drive side.
Standard direction of rotation of the motor is counterclockwise (CCW) in case that the phase sequence of power supply side is R, S, T and when these phases are connected with the motor terminal symbols U, V, W.

3.4 Checking of wiring

- (1) Terminals must be connected correctly in accordance with connection diagrams (Fig. 5, Fig. 6). Due attention should be paid to the following points.
 - 1) For the signal cable between pulse oscillator (PG) and controller, the twisted pair, shielded cable should be used for protection against noise. The length should be 100m or less. Also, connection with pulse oscillator of motor side is connector connection and therefore, undermentioned straight plug and cable clamp are needed in addition to the cable.
 Recommendable cable ... Twisted pair, shielded cable ... CO-SPEV-SB(A)7P-0.5SQ
 (product of Hitachi Metals, Ltd.)
 Straight plug ... MS3106B-20-29S
 (product of Japan Aviation Electronics Industry, Limited or equivalent)
 Cable clamp ... MS3057-12A
 (product of Japan Aviation Electronics Industry, Limited or equivalent)
 - 2) As to the shielded cable (N), ground that of the motor side only.
 - 3) Never carry out the measurement of insulation resistance (Megger test) of pulse oscillator.
Use tester for this measurement.
 - 4) For the wiring cable of ptc thermistor, use twisted pair cable.
 - 5) The earthing terminal (E mark terminal) provided in the main terminal box must be grounded. The earthing terminal (E mark terminal) is provided also in the auxiliary terminal box for cooling fan. Please ground it surely.
- (2) Checking of the direction of rotation of electric fan
After finish of wiring work, check that the electric fan for cooling rotates to the correct direction, before starting of normal operation. (direction of rotation and cooling air flow are indicated on the fan cover.)

3.5 Detailed drawings of terminal boxes

Main terminal box (Fig. 7) and cooling fan terminal box (Fig. 8) are terminal block type. However, for the motors EDM43 or over, main terminal box is lug type.

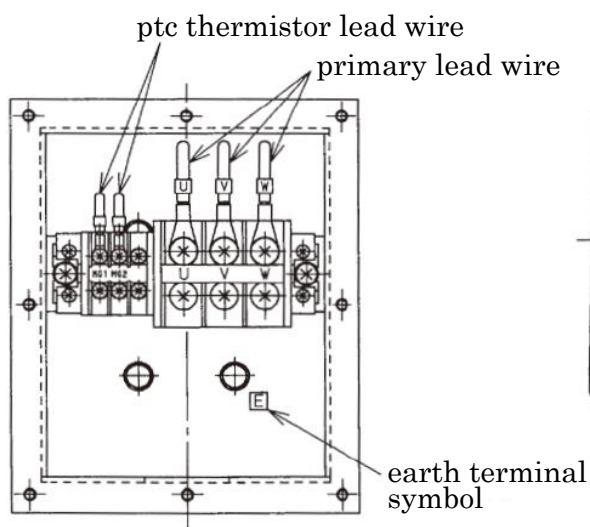
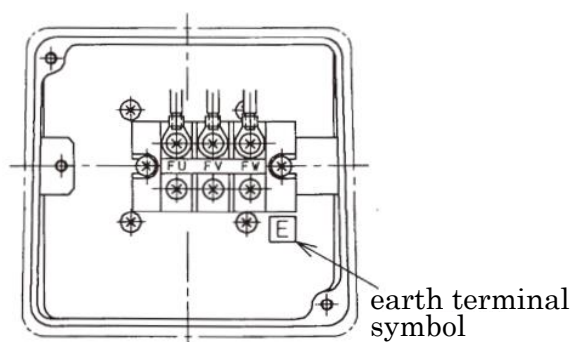

Fig. 7 Detailed drawing of main terminal box



In case of single phase, terminal symbols are FU and FV.

Fig. 8 Detailed drawing of cooling fan terminal box

II. Trial operation and ordinary operation

1. Before powering

All of your purchased motors from us passed severe tests at our factory however, they may have a possibility of being damaged during transportation or affected by long storage, and so carry out following checking, confirmation before starting of operation.

(1) Precautions for working before trial operation

- 1) Check that the shaft fixer and cover for the time of storage were removed.
- 2) Check whether electric wiring was correctly carried out and terminal box cover was fitted.
- 3) Check whether loose tightening bolts are found at individual part.
- 4) Check whether the motor is well ventilated.
- 5) Check whether rotating part contacts fixed part when the shaft is rotated manually.
- 6) Measurement of insulation resistance of stator coil to earth. Disconnect the motor main circuit at the terminal block of the controller side and measure insulation resistance using 500V Megger between motor terminal and earth. Although it is difficult to generally indicate the insulation resistance value, criterion is $1M\Omega$ or over.
- 7) Check whether earth terminals of individual part are completely connected.

(2) Lubrication

For the grease lubrication type motors, the bearing portion is filled with grease before shipment. However, if they are not used for more than 6 months after arrival at the site, the grease must be replenished soon after starting of operation. This work is not necessary in case of use of sealed-grease type bearing.

(3) Others

Check the status of direct connection and belt tension as well as tightening of bolts and nuts of the individual part.

2. After powering

(1) In the initial operation, the motor should be operated with no load independently at as low as possible speed in order to confirm no abnormality. After that, the motor should be connected with the counterpart machine.

(2) After starting of operation, check the following points.

- 1) Whether direction of rotation (standard direction of rotation is clockwise as seen from non-load side) is correct.
- 2) Whether abnormal sound is heard from the bearing part.
- 3) Whether abnormal sound is heard from inside of the motor.
- 4) Whether burning smell of insulator, etc. is sensed.
- 5) Whether abnormal vibration is sensed. If the total amplitude exceeds $30\mu\text{m}$, investigate the cause and take necessary measures.
- 6) Whether supply voltage and phase current are balanced.
- 7) Whether starting time is abnormally long.

Checking the above points, proceed independent operation, no-load operation, full-load operation sequentially and if all of them are normal, start full scale operation.

III. Maintenance, checking

In order to prevent accidents in operation of the machine, daily monitoring or checking is required.

1. Daily checking

By touching and hearing, check the vibration and sound at the time of starting and during operation of the machine and confirm that there is no abnormality. User is recommended to put the status of operation on record.

Records of daily checking :-

- (1) Date, time of measurement. Weather of the day of measurement
- (2) Voltage, load current, frequency, rotation speed
- (3) Ambient temperature
- (4) Temperature of stator winding or frame
- (5) Temperature and sound of bearing
- (6) Abnormal vibration
- (7) Cooling air condition of cooling fan

2. Periodical checking

- (1) Measurement of insulation resistance
- (2) Checking of bearing related items
- (3) Condition of ventilation
- (4) Measurement of vibration
- (5) Looseness of tightening nuts
- (6) Condition of direct connection of coupling and belt tension
- (7) Cleaning of individual part
- (8) Checking of power supply condition
- (9) Checking of pulse oscillator, cooling fan

Checking items are as shown above. The insulation resistance should be measured every 6 months and the other items should be checked once a year.

To measure and monitor the machine vibration periodically is very important for the maintenance/checking of the machine. If vibration is large, it affects the bearing, winding and condition of direct-connection badly and therefore, investigate the cause and repair the faulty part.

3. Bearing and lubrication

3.1 Shielded bearing

For the motors of EDM13~EDM22 and EDM27~EDM35 (non-load side), shielded type ZZ (non-contact type sealed grease) bearing is used. Generally, the bearing should be replaced at the time of periodical checking. Until that time, grease maintenance is not required.

3.2 Grease replenish type bearing

For the motors of EDM43 or over, kind, quantity and interval of replenishing of grease are indicated on the name plate.

- (1) Replenish the grease during operation at every replenishment interval (operation time) indicated on the name plate. In case that the net operation time is short due to short-time or repetitive operation, grease should be replenished in such a way that the elapsed time including stoppage will not become twice or more of the interval indicated on the name plate, or at least every 6 months - one year.
- (2) When grease is replenished, be sure to rotate (300 r/min or more) the motor, clean the grease nipple, and replenish necessary quantity by grease gun through the nipple. At every time of grease replenishment, scrape out old grease from grease drain port.
- (3) When the grease is replenished, bearing sound will become temporarily louder a little or the bearing temperature will rise 5°C~10°C higher than the normal one, because of excess grease, but it will return to normal one in several hours to 1 day.
- (4) Table 4 shows approximate values of grease replenishment quantity and replenishing timing.

Table 4 Grease replenishment quantity

Type of motor	Load side bearing No.	Replenishment quantity (g)	Replenishing timing (cumulative operating time) (Hr) at specified speed		
	Non-load side bearing No		1800 r/min	1500 r/min	1200 r/min
EDM2761V	NU313	33	3400	4200	5400
EDM2771V	6312ZZ	--	--	--	--
EDM2772V	NU316	47	3000	3700	4800
EDM2781V	6312ZZ	--	--	--	--
EDM3141V	NU316	47	3000	3700	4800
	6315ZZ	--	--	--	--
EDM3151V	NU320	72	2600	3200	4200
EDM3161V	6315ZZ	--	--	--	--
EDM3541V					
EDM3551V	NU324	102	2300	2900	3700
EDM3561V	6318	24	2300	2900	3700
EDM43**V					
EDM54**V	6324	102	4700	5800	7600
	6318	48	4700	5800	7600
EDM68**V	6326	116	4400	5500	7200
	6324	96	4400	5500	7200

Table 5

At the forwarding from our factory, bearings are filled with Multemp SRL (of Kyodo Yushi Co.) unless otherwise specified, (or grease of the brand specified by user). For replenishment of grease, we recommend this Multemp SRL. If grease of this brand is not obtainable, the equivalent greases shown in the table below can be used.

Maker name	Brand of grease
Kyodo Yushi	Multemp SRL
Nippon Oil	Multi Knock Wide 2
MOBIL	Mobil Temp SHC100
SHELL	Variant M2
ESSO	Templex N2

3.3 Use of grease of different type for the grease replenish type bearing

- (1) Avoid mixed use of different brands of grease. Depending on the combination, properties of grease may greatly change.
- (2) In case that the user is compelled to use a grease of different brand from the grease of the time of delivery, the following method should be taken.
 - 1) Open the grease drain port and inject new grease while scraping out the old grease, during operation or by manual rotation of the shaft.
 - 2) Repeat this work until the new grease comes out of the grease drain port.
- (3) When the grease is injected, bearing temperature may rise. In such a case, stop the injection until lowering of bearing temperature. After that, repeat the injection of the grease.

3.4 Sound of bearing (Grease replenish type)

Sound of bearing during operation is classified as follows.

(1) Normal sound

The normal sound is continuous one. The race sound, jarring sound and retainer sound are considered as normal. The jarring sound may be misunderstood as an abnormal noise but it does not mean the abnormality of bearing. The jarring sound dies away temporarily when the grease is injected in general.

The jarring sound may be generated in the following cases.

- 1) In case of bearing clearance C3 or C4 for high speed machine
- 2) In case of cylindrical roller bearing
- 3) In case of operation in winter of low ambient temperature and of the beginning of operation after long stoppage.

(2) Abnormal sound

- 1) Flaw noise or dust noise, etc. are abnormal sound.
- 2) Abnormal sound is discontinuous and in some cases it accompanies vibration.
- 3) When abnormal noise sounds, inject new grease and observe change in sound and temperature for a while. If abnormal noise does not stop, the bearing should be replaced.

4. Checking of accessories

For checking of accessories of electromagnetic brake, speed reducer, etc., see the Instruction of Manual for accessories of the separate volume.

5. Service life of main accessory parts

Some parts of motor have their service life limit. It differs depending on the service environment/conditions and therefore, carry out checking or replacement of parts making the undermentioned service life limit as a criterion.

5.1 As to motor related parts

(1) Motor bearing (at ambient temperature of 40°C or lower and speed of 1800 r/min)

- 1) Grease replenish type bearing About 50,000 hours
- 2) Shielded bearing About 32,000~ 47,000 hours
 - Sealed grease is of Multemp SRL of Kyodo Yushi, or equivalent.
 - Life of shielded bearing is determined depending on the life of sealed grease. Life of sealed grease is affected by the ambient temperature and is shortened about 1/1.5 every time the ambient temperature rises 10°C from 40°C.

(2) Fan motor About 3~4 years (at ambient temperature of 40°C or lower)

(3) Pulse oscillator ... About 4~5 years (at ambient temperature of 40°C or lower and speed of 1800 r/min)

(The shielded bearings of fan motor and pulse generator will reach the limit of their service life. This limit differs depending on the ambient temperature.)

(4) V ring About 25,000 hours

(It is recommended to also replace the V-ring when the encoder is replaced.)

5.2 Helical speed reducer (at ambient temperature of 40°C)

(1) Each bearing About 25,000 hours

(2) Oil seal About 10,000~15,000 hours as a criterion (Life differs greatly depending on the environmental conditions for use.)

(3) Replacement cycle of lubrication oil

First time : 500~1,000 hours after starting of operation.
Subsequently : Every 2,500 hours.

IV. Storage

1. Storage

(1) In case that the motor is stored for 3 months or longer till the initial operation after receiving it or its operation is stopped for 3 months or longer, take the following steps.

- | | |
|-------------------------------------|--|
| 1) Storage | : The motor should be placed in the same posture with correct installation state, covered with waterproof sheet, and be kept at a dry place. |
| 2) Exposed machined surface | : Apply rust-preventive agent every 6 months. If motor is export-packed, unpack it after elapse of one year and apply the rust-preventive agent. |
| 3) Rotation of shaft | : Operate the motor for a few minutes every 3 months (and before long storage) or rotate the shaft manually about 10 times. If motor is export-packed, follow item 4) below. |
| 4) Bearing and lubrication | |
| • Shielded bearing | : After storage of motor for 2 years or longer, pay attention whether abnormal sound is heard from bearing during trial operation. If it is heard, replace the bearing. |
| • Grease replenishment type | : Replenish the quantity shown on the name plate, rotating the shaft manually or operating the motor every one year. (If the motor is export-packed, unpack it temporarily and replenish the grease.) |
| 5) Insulation resistance of winding | : In case that the motor is not used for a long time, measure the insulation resistance of winding of the winding every 6 months and before starting of operation. If resistance is lower than 1 MΩ at ordinary temperature and its cause is not the moisture adsorption in the terminal box, dry the winding. |
| 6) Space heater (when provided) | : When the motor is stopped for 1 day or longer, energize the heater. |
| 7) Surface painting | : Re-paint every 2 years, as the need arises. |
| 8) Drain plug (when provided) | : Open the drain plug periodically (at least every 6 months) and before starting of operation. |

V. Disassembly, Assembly

This motor incorporates permanent magnet in its rotor. Owing to this composition, pulling out of the rotor from the stator is quite difficult. Therefore, do not pull out the rotor from the stator at the time of disassembly/assembly of motor, such a case of replacement, etc. of bearing. Replacement of bearing can be carried out keeping the rotor inserted in the stator. Also, at the time of disassembly/assembly, do not proceed the work at load side and non-load side simultaneously. Surely after completion of work of one side, start the work of the other side (As to the order of work, starting from any of both side is available). Since magnetism of the magnet of rotor acts to outside a little during the works of disassembly/assembly of motor, do not make Watch, Magnetic Card, etc. approach to the motor.

1. Disassembly/assembly procedures

(See Fig. 9 below and structural sectioned drawings (Fig. 17~Fig. 20)

- (1) Break the power supply.
- (2) Remove the connection with the load.
- (3) Remove all the external wirings connected with the terminals in the terminal box.
- (4) Remove the connection part of pulse oscillator output cable connector at upper part of fan cover.

1.1 Non-load side

- (1) Remove pulse oscillator output cable connector from fan cover.
- (2) Remove fitting bolts of fan cover and remove fan cover. At this time, cooling fan installed at fan cover is also removed in combined state with fan cover.
- (3) Remove fitting screws of pulse oscillator cover and remove pulse oscillator cover. At this time, pulse oscillator output cable is led from lower part of pulse oscillator and therefore, pay attention not to be pulled this cable.
- (4) Remove screws, which fix the plate spring of pulse oscillator stator to the mount of pulse oscillator.

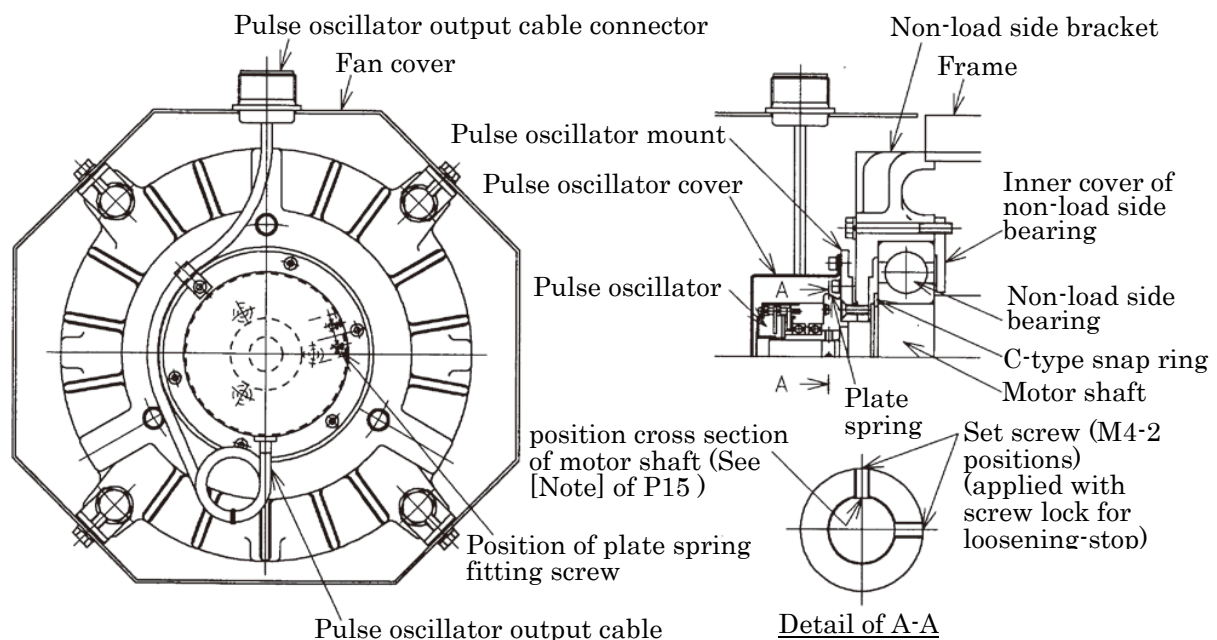

Fig. 9 Detailed drawing of non-load side pulse oscillator and bearing part

- (5) Loosen about 3 turns the 2 setscrews fixing the pulse oscillator rotor to the motor shaft and remove pulse oscillator. (Do not take off the setscrews.) However, an adhesive (TB1342H) is used to prevent the set screws from loosening. Before removing the set screws forcibly, warm them up to about 100°C using a thin soldering iron and then remove them.
- (6) Remove the fixing screws of the pulse oscillator mount, and remove that mount. When the mount is removed, mark the matchmarks. (For EDM22~EDM68, it is unnecessary to remove the pulse oscillator mount.)
- (7) Remove the V-ring. Refer to Fig. 10 for motors with encoder only (EDM3551V and EDM3561V, EDM43 to EDM68), and motors with encoder and electromagnetic brake. At that time refer to Table 6 for the V-ring type on the non-load side.

Remove the V ring.

- (8) In case that the electromagnetic brake is provided, remove it.
- (9) Remove the bearing outer cover of non-load side (since the cover of EDM35 or less is unified type with bracket, remove the fixing bolts of the bearing inner cover). When that outer cover is removed, mark the matchmarks.
- (10) Remove the bracket of non-load side. When it is removed, mark the matchmarks.
- (11) Remove the insulated short shaft (this shaft is attached to EDM31 or over and not attached to EDM27 or less, of which shaft is unified type with motor shaft.) of non-load side shaft end. When that short shaft is removed, mark the matchmarks.
- (12) Remove the C-type snap ring by the pliers. (EDM35 or less)
Remove the bearing nut, bearing washer and outer slinger. (EDM43 or over)
- (13) Pull out the bearing from shaft by the puller. (As to the details of replacement work of bearing, refer to item V-2.)
- (14) After completion of replacement work of bearing, carry out assembly work under reversed procedure of disassembly. **Align** the matchmarks marked at the time of disassembly and tighten the bolts of diagonal positions alternately in order to avoid uneven tightening. Also, apply grease (Three Bond 1805 spray type) to the lip of the V ring. The shaft runout for mounting the encoder should be 0.05 mm or less at TIR. The measurement method of shaft runout is according to Fig.11. At that time, use a non-magnetic dial gauge. If the dial gauge is not nonmagnetic, it may not be possible to measure shaft runout correctly.

[Note]

T.I.R.(Total Indicator Reading) refers to the total amount of dial gauge reading when the measurement unit is rotated once around the reference axis.

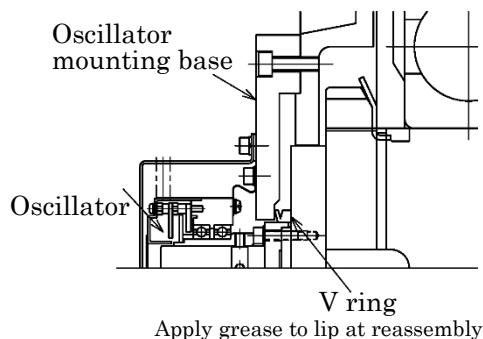

Fig.10 Position of V ring at non-load side

The shaft runout correction method is as follows.

- (a) If the encoder mounting shaft is integral with the motor shaft (Refer to Fig.12 (a)), adjust by tapping the shaft end with a plastic hammer (Less than 2LB) and a rod of soft material that does not damage the shaft. (For example, Duracon) Be careful as the impact may cause an abnormality if the shaft is subjected to an extremely strong impact.
- (b) If the encoder mounting shaft is fixed to the motor shaft with bolts (Refer to Fig.12 (b)), loosen its bolts and adjust the mounting position. Be careful not to forget to tighten the bolt tightly at the end.
- (15) After assembling, rotate the shaft manually to confirm smooth rotation.

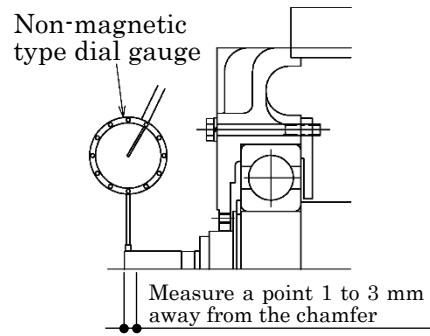

Fig.11 Runout measurement of oscillator mounting shaft

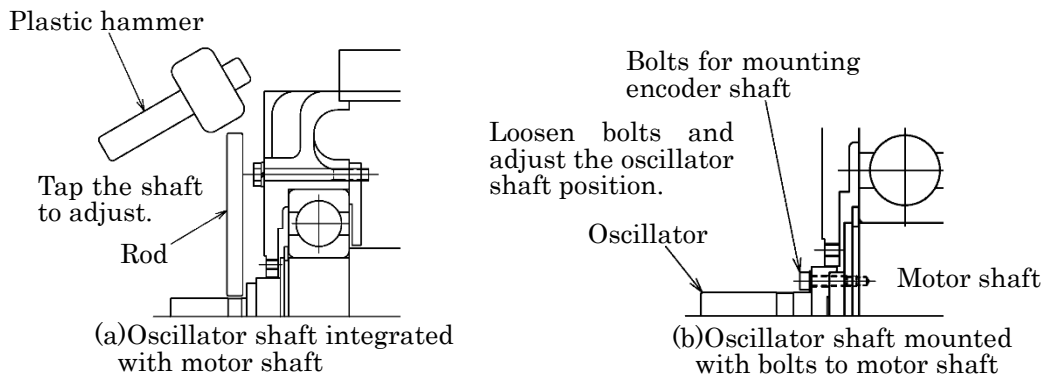

Fig.12 Shaft runout correction method

Table 6 V ring type on the non-load side (Only motors with an oscillator)

Type of motor	Type of break	Type of V ring
EDM1311V~EDM3541V	None	None
EDM3551V~EDM6851V		V-40A
All types	MNB-5K	V-28A
	MNB-10K	V-28A
	MNB-20K	V-32A
	MNB-40K	V-45A
	SNB-1.2K	V-18A
	SNB-2.5K-13	V-22A
	SNB-6KB-03	V-28A
	SNB-12KB-03	V-28A
	SNB-25KB-03	V-32A
SNB-45KB-03	V-40A or V-38A	

1.2 Load side

- (1) Remove the bearing outer cover of load side. (For EDM22 or less, this cover is unified unit with bracket.) In addition, since the V ring is attached in the case of waterproof specification, remove the V ring. Refer to the outline drawing to identify the type of V-ring.
- (2) Pull out the slinger of bearing outer side of load side from the shaft. Slinger is fixed to the shaft by screw at one position. (Motors, to which the outer slinger is attached, are EDM31 or over)
- (3) Remove the bracket of load side. When it is removed, mark the matchmarks. As to the motors EDM27~EDM43 using roller bearing, pay attention since bearing outer ring also is pulled out together.
- (4) Pull out the bearing from the shaft by puller. (As to the detail of replacement work of bearing, refer to item V-2.)
- (5) After completion of disassembly, wash off the grease on the bearing and bearing cover, etc. by clean washing oil. (This work is unnecessary for the shielded bearing.)
- (6) Fill the cleaned bearing or replaced bearing with grease, turning the outer ring.
Fill the bearing cover with grease of about 1/2 to 1/3 of the capacity. (This work is unnecessary for the shielded bearing.)
- (7) Carry out assembly work under reversed procedure of disassembly procedure. Align matchmarks marked at the time of disassembly and tighten the bolts of diagonal positions alternately in order to avoid uneven tightening. Apply grease (Three bond TB1805 spray type) to the lip of V ring.
- (8) After assembling, rotate the shaft manually to confirm smooth rotation.

[Note]

- 1) Giving the impact to the pulse oscillator will cause trouble. Never hit it with hammer, etc. Since clearance fit is adopted for engaging of pulse oscillator rotor and shaft, they can be pulled out manually.
- 2) Even for the cases of removing and re-mounting of pulse oscillator at the times of replacement, etc. of bearing or pulse oscillator, setscrew position for fixing the pulse oscillator rotor is determined to make that the magnetic pole position detection of the rotor of motor is same. As shown in Detail of A-A Cross Section of Fig. 9 of Page 12, when one of 2 positions of setscrew M4 is coincided with flat cut position of motor shaft (one position of motor shaft, where setscrew contacts, is flat surface), mount the other setscrew arranging that it surely comes to the position turned 90° to counterclockwise seen from the non-load side shaft end (position where motor shaft is not cut flatly).
As to motors EDM31 or over, the part where pulse oscillator rotor is inserted, is an insulated short shaft. When this insulated short shaft is removed from motor shaft, be sure to mark the matchmarks. (After mounting, confirm that the direction of keyway position of output shaft of motor shaft and flat cut position of insulated short shaft is same.)

2. Replacement of bearing

2.1 Removal of roller bearing inner ring and ball bearing

- (1) The pliers is used for removing the C-type snap ring and the puller for removing the slinger and bearing.
- (2) For the roller bearing, apply a brass or copper plate to the outer ring and alternately hit it at diagonal positions on the circumference with a hammer to remove it from the shield. (Fig.13)
- (3) Pull out the ball bearing (Fig. 14) and roller bearing inner ring (Fig. 15) with a puller. In case of grease-replenish type structure, pull out above parts together with bearing inner cover and inside slinger.

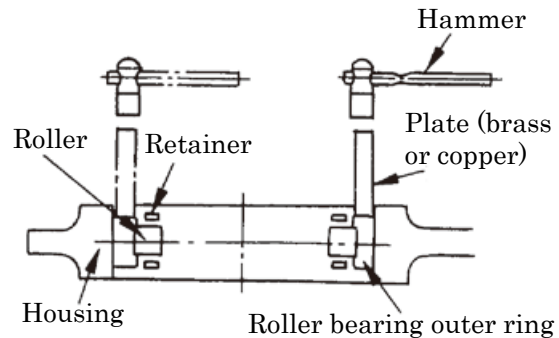

Fig.13 Removal of roller bearing outer ring

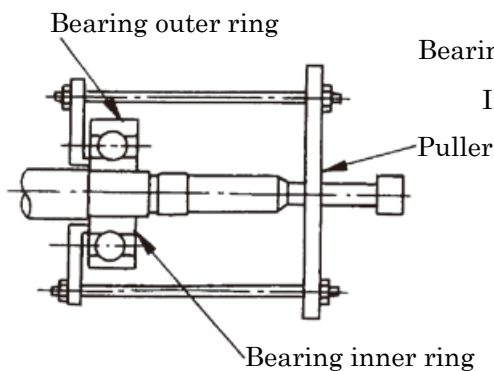

Fig.14 Removal of ball bearing

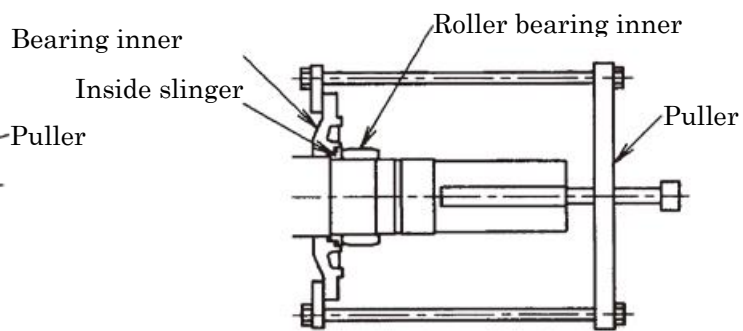

Fig.15 Removal of roller bearing inner ring

2.2 Mounting of bearing

- (1) New bearings packed and stored should not be unpacked until they are used.
- (2) Thinly apply the grease to the inner surface of the housing, in which the bearing is mounted.
- (3) Before insertion of bearing, mount bearing inner cover (if provided) and inside slinger (if provided) to the shaft. Similar to the bearing, make shrink fit of inside slinger to the shaft, referring item (4).
- (4) Heat the ball bearing or roller bearing inner ring in oil, thermostatic oven or by induction heater to about 80°C and insert it onto the shaft. Be careful not to over-heat it. For the shielded bearing, method of heating in oil should not be applied.
- (5) Filling quantity of grease for grease-replenish type In order to fill the grease in the clearance of the bearing itself and further in the grease injection passage, inject the replenishment quantity indicated on the name plate after assembling of rotary machine.

[Note]

After replacement of bearings of non-load side and load side (EDM27 or over), fit the stud (2 pcs.) to the holes for the bracket fitting bolt of bearing inner cover, before mounting of the bracket. By this work, bearing cover fitting bolt can be fitted easily. (See Fig.16)

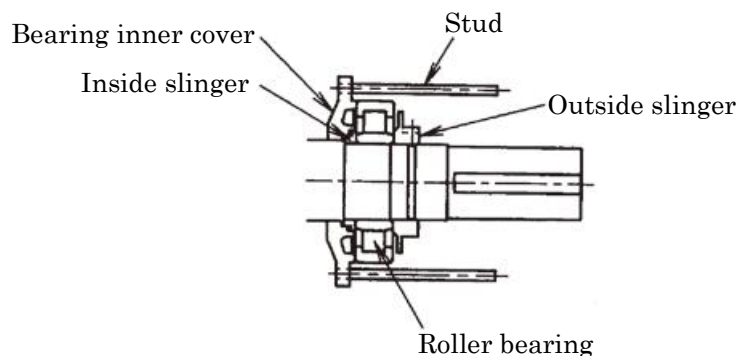

3. Structural drawing of motor

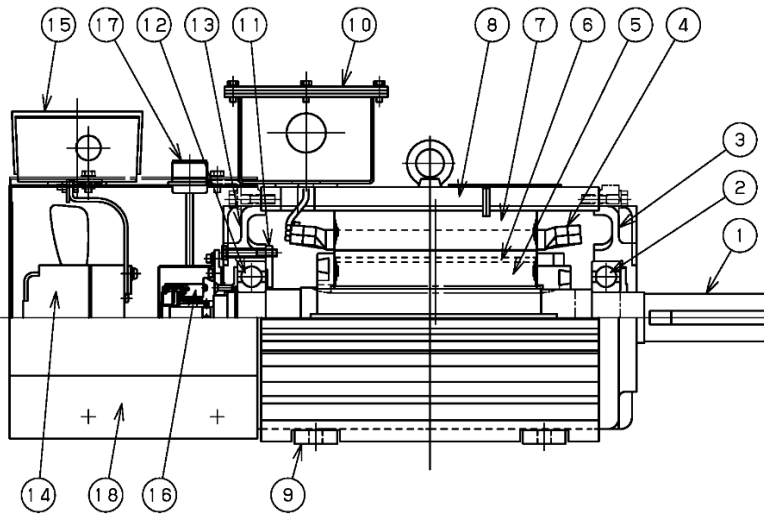

Fig.17 Structural sectioned drawing of EDM22 or less

Table 7

No.	Name
1	Shaft
2	Load side double shielded ball bearing
3	Load side bracket
4	Stator coil
5	Rotor
6	Permanent magnet
7	Stator
8	Frame
9	Foot
10	Main terminal box
11	Non-load side bearing inner cover
12	Non-load side double shielded ball bearing
13	Non-load side bracket
14	Electric cooling fan
15	Terminal box for electric cooling fan
16	Pulse oscillator
17	Pulse oscillator output cable connector
18	Fan cover

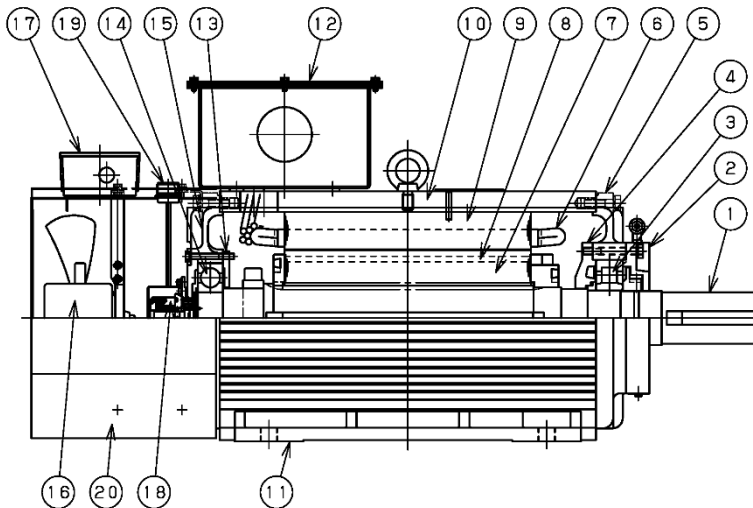

Fig.18 Structural sectioned drawing of EDM27~EDM3541V

Table 8

No.	Name
1	Shaft
2	Load side bearing outer cover
3	Load side roller bearing
4	Load side bearing inner cover
5	Load side bracket
6	Stator coil
7	Rotor
8	Permanent magnet
9	Stator
10	Frame
11	Foot
12	Main terminal box
13	Non-load side bearing inner cover
14	Non-load side double shielded ball bearing
15	Non-load side bracket
16	Electric cooling fan
17	Terminal box for electric cooling fan
18	Pulse oscillator
19	Pulse oscillator output cable connector
20	Fan cover

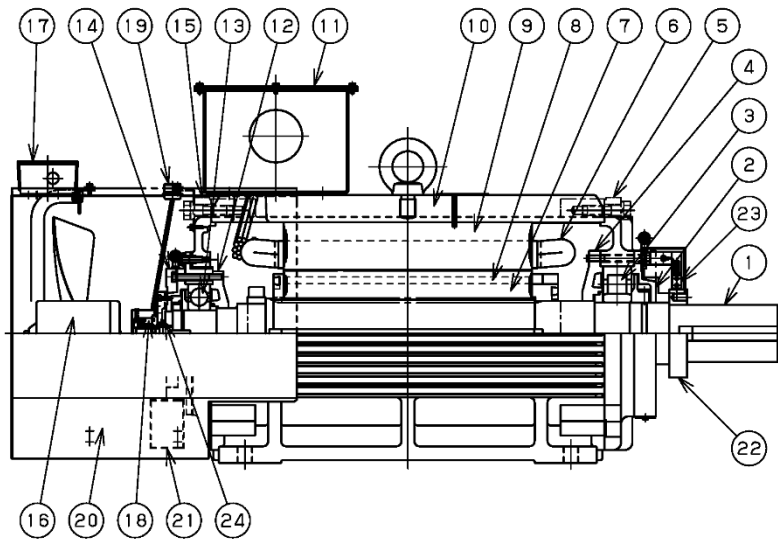

Fig.19 Structural sectioned drawing of EDM3551V, EDM54

Table 9

No.	Name
1	Shaft
2	Load side bearing outer cover
3	Load side roller bearing (EDM35~EDM43) Load side ball bearing (EDM54)
4	Load side bearing inner cover
5	Load side bracket
6	Stator coil
7	Rotor
8	Permanent magnet
9	Stator
10	Frame
11	Main terminal box
12	Non-load side bearing inner cover
13	Non-load side ball bearing
14	Non-load side bearing outer cover
15	Non-load side bracket
16	Electric cooling fan
17	Terminal box for electric cooling fan
18	Pulse oscillator
19	Pulse oscillator output cable connector
20	Fan cover
21	Grease reservoir
22	Slip ring
23	Earth brush
24	V ring

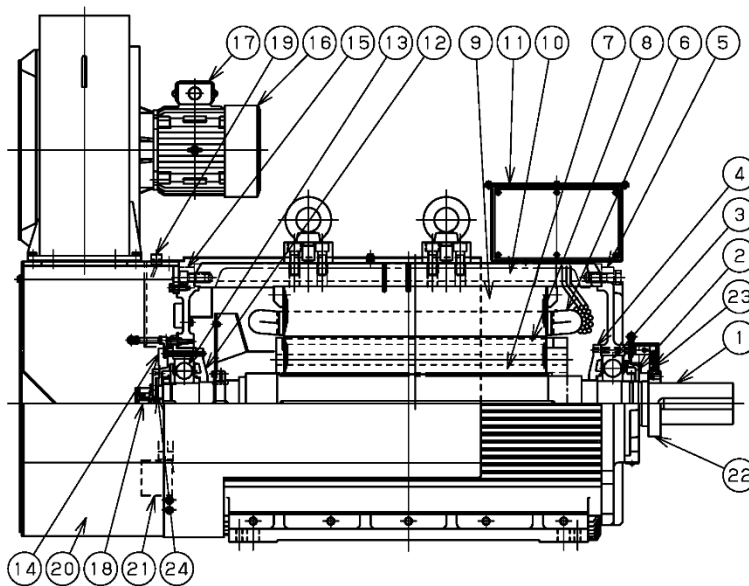

Fig.20 Structural sectioned drawing of EDM68

Table10

No.	Name
1	Shaft
2	Load side bearing outer cover
3	Load side ball bearing
4	Load side bearing inner cover
5	Load side bracket
6	Stator coil
7	Rotor
8	Permanent magnet
9	Stator
10	Frame
11	Main terminal box
12	Non-load side bearing inner cover
13	Non-load side ball bearing
14	Non-load side bearing outer cover
15	Non-load side bracket
16	Electric cooling fan
17	Terminal box for electric cooling fan
18	Pulse oscillator
19	Pulse oscillator output cable connector
20	Fan cover
21	Grease reservoir
22	Slip ring
23	Earth brush
24	V ring

VI. Troubleshooting of Motor

If the daily checking and periodical checking in III. Maintenance/Checking are correctly done, the motor satisfactorily works. Table 11 shows "Motor Troubleshooting" and Table 12 "Bearing Troubles and Causes". They should be referred to for daily maintenance/checking.

Table 11 Motor Troubleshooting

Cause		Phenomena	Shaft breakage	Loud noise/large vibration	Over heat		Uneven rotation	Protective relay operation	Leakage	Insulation resistance low	Remedy
					Motor	Bearing					
Installation	Place	Ambient temperature is high			◎	○		◎			Ventilate well
		Humidity is high							○	◎	Consult maker
		Splashing of much water/oil				○			○	◎	Prevent splashing
		Obstruction close to motor			◎	○		○			Secure necessary space
		Large external vibration/impact		◎		○					Vibration proofing
	Weak foundation			◎							Strengthen it
Coupling with load	Direct coupling	Misalignment	○	◎		○					Align correctly
		Large unbalance of coupling		◎							Correct balance of coupling
	Belt	Misalignment of center between pulleys		◎			○				Align the center
		Contact angle is small	◎			○					Make proper pulley diameter
		Excessive tension of belt	◎			◎					Make proper belt tension
		Load point too away from motor	◎			○					Put load point nearer the motor
		Large pulley impedes cooling air of motor			◎			○			Provide vent hole for pulley
	Others	Dust on rotating portion		◎		○					Remove dust
		Large axial load				◎					Review axial
Wiring	Large voltage drop				◎		○	◎			Investigate wiring diameter/length
	Loosened terminals				◎		○	○			Retighten terminals
	Incomplete earthing							○	◎		Complete earthing
	Single-phase operation			◎	◎			◎			Investigate connecting circuit
	Voltage unbalance			◎	○			○			Investigate control side
	Wrong wiring of cooling fan				◎	○					Change connecting circuit
	Wrong wiring of pulse oscillator							◎			Change connecting circuit (If trouble occurs with pulse oscillator, replace it)
Load	Overload			○	◎			◎			Reduce load
	Large number of starts		○		◎			○			Reduce number of starts
	Large inertia of load				◎			○			Extend acceleration time
	Large vibration of counterpart machine			◎							Investigate counterpart machine
	Large unbalance of load			◎	○						Correct balance
Others	Bearing abnormality (motor)			◎		◎		○			Repair at specialized factory
	Disconnection of stator coil (motor)			○	○			◎	◎	◎	Repair at specialized factory
	Abnormal bearing of cooling fan			○	◎	○	○	◎			Replace cooling fan
	Disconnection of winding of cooling fan				◎	○		◎			Replace cooling fan
	Abnormal bearing of pulse oscillator							◎			Replace pulse oscillator
	Circuit failure of pulse oscillator							◎			Replace pulse oscillator

Table 12 Bearing Troubles and Causes

Phenomena	Condition	Cause	Remedy
Flaking	① Flaking of rolling element	① Excessive interference ② Wrong selection of clearance ③ Operation clearance minus ④ Expansion due to temperature Inclusion of dust, foreign matter or rusting/dent	① Caution in assembling or making shaft/bearing housing ② Review of clearance ③ Handling care in assembling ④ Investigation of service condition
	② Local flaking of raceway track ③ Flaking over entire circumference of raceway track ④ Flaking of place opposite to raceway track	① Elliptic distortion of shaft or bearing housing ② Faulty tightening ③ Faulty machining accuracy ④ Secular change, abnormal thrust load	Investigation of machining accuracy of shaft/bearing housing, investigation of tightening amount
	⑤ Flaking over entire circumference off center of raceway track ⑥ Flaking diagonally crossing raceway track ⑦ Rolling element pitch-like flaking on raceway track	① Warp of shaft ② Oblique installation of inner/outer rings	Investigation of design of bearing surrounding Investigation of design of bearing surrounding Investigation of service conditions
Electrolytic corrosion	Crater-like concave, washboard-like flaw	Current passing	Investigation of design of bearing surrounding
Wear	① Extreme wear of raceway track/rolling element ② Wear of cage	① Foreign matter in lubricant ② Rusting	Investigation of lubricant and lubrication amount
	① Concave (raceway track, etc.) ② Ground-like ③ Impact during handling ④ Flaw caused when assembling	Dust/foreign matter rolled between rolling element and raceway track Careless handling (dropping, etc.) Careless assembling	Investigation of working conditions when handling or assembling Careful handling Correct assembling
Damaged cage	① Damage ② Biased wear ③ Wear of pocket portion ④ Galling	① Moment load ② High-speed rotation ① Lubrication failure ② Foreign matter	Careful handling and review of service conditions Investigation of lubrication amount or lubricant
	① Discoloring/softening of raceway track ring/rolling element ② Damage	① Clearance is too small ② Insufficient lubrication ③ Improper lubricant Overload	① Investigation of proper clearance ② Investigation of lubrication amount and lubricant ③ Review of service conditions ④ Investigation of handling
Smearing	Galling of raceway track or rolling element surface	① Lubrication failure ② Inclination of rolling element (skewing) ③ Selection of lubricant	Investigation of lubricant/lubricating conditions
Creep	Wear, slipping, or discoloring of inside/outside diameter surface	① Insufficient interference of engagement ② Insufficient tightening of sleeve	① Investigation of tightening amount ② Investigation of machining accuracy of shaft/bearing housing ③ Design investigation
Cracking/chipping	① Cracking ② Mis-cutting	① Progress of impact/strike flaking ② Large interference Large R of installation	① Careful handling ② Investigation of tightening amount ③ Investigation of machining accuracy of shaft/bearing housing
	① Rusting over entire surface ② Partial rusting ③ Contact corrosion of engaged surface	① Wrong storage condition ② Leaving to stand ③ Improper cleaning ④ Rust preventive agent ① Improper packing ② Sweat ① Insufficient interference ② Fluctuating load	① Investigation of storage place ② Caution in handling ③ Investigation of rust preventive agent ① Review of machining of shaft-bearing housing ② Review of service conditions

VII. Industrial Product Warranty

1. Free of Charge Warranty Period

The free of charge warranty period shall be “less than 1 year after installation in your company or your customers” or “less than 18 months after shipment from the factory or storage warehouse”, whichever comes first. In case of repair, overhaul or other maintenance by Toyo Denki or a company designated by Toyo Denki, the warranty period for the parts concerned shall be for 1 year from the date of acceptance inspection.

2. Warranty scope

(1) Problem diagnosis

As a general rule, initial diagnosis in the event of product failure should be performed by your company. However, if you request initial problem diagnosis, it can be performed on your behalf by Toyo Denki or a member of our service network. Please note that if Toyo Denki is not responsible for the cause of the failure, a fee will be charged for the initial diagnosis.

(2) Repair

Repair, part replacement, and onsite repair shall be provided free of charge. However, this shall not apply in the following cases:

- ① When the problem is a result of improper product handling, conditions, environment, usage method, etc., by you or your customer
- ② When the problem was caused by a system designed by you or your customer
- ③ When the problem was caused by deficiencies in a program created by you or your customer
- ④ When the problem originated in something other than the delivered product
- ⑤ When the problem was caused by modification performed without the prior approval of Toyo Denki
- ⑥ When the problem was caused by repair or modification performed by someone other than Toyo Denki or a company designated by Toyo Denki
- ⑦ When the problem was caused by a force majeure such as a natural disaster, fire, or accident.
- ⑧ Other cases where Toyo Denki is not responsible for the cause of the problem
- ⑨ The free of charge warranty period has expired

3. Disclaimer

Irrespective of whether the free of charge warranty period is in effect, this warranty shall not compensate you or your customer for any damages that are not the responsibility of Toyo Denki, or for any lost opportunity, lost profit, secondary damages, or accident due to the failure of the Toyo Denki product concerned. Moreover, compensation shall not be provided relating to articles other than the Toyo Denki product concerned.

4. Repair period after product discontinuation

Once the product has gone out of production, Toyo Denki will continue to provide repair service for the product for a period of seven years. However, please note that the procurement of electronic components for the product may become difficult during that time, and repair may not be possible.

5. Delivery conditions

In the case of standard products ordered without test operation and adjustment, delivery shall take place upon product arrival at your company, and Toyo Denki shall not be responsible for onsite test operation and adjustments.

TOYODENKI SEIZO K.K.

<https://www.toyodenki.co.jp/>

HEAD OFFICE: Tokyo Tatemono Yaesu Bldg, 1-4-16 Yaesu,
Chuo-ku, Tokyo, Japan ZIP CODE 103-0028

TEL: +81-3-5202-8133

FAX: +81-3-5202-8150

A part of specification and dimension is subject to change without notification in advance because of improvement of product, for which please understand.

TIM101 [A]_20190527_1000K