

OPCN66-Z Communication Protocol Manual	No.	QG18745
	Issued Department	Industrial Business Division Industrial System Works Industrial Development Department

Mark	Date	Records	Applied No.	Pages of Correction	Approved	Designed	Drawn
-	2011/1/31	Writing Issue	X	—			

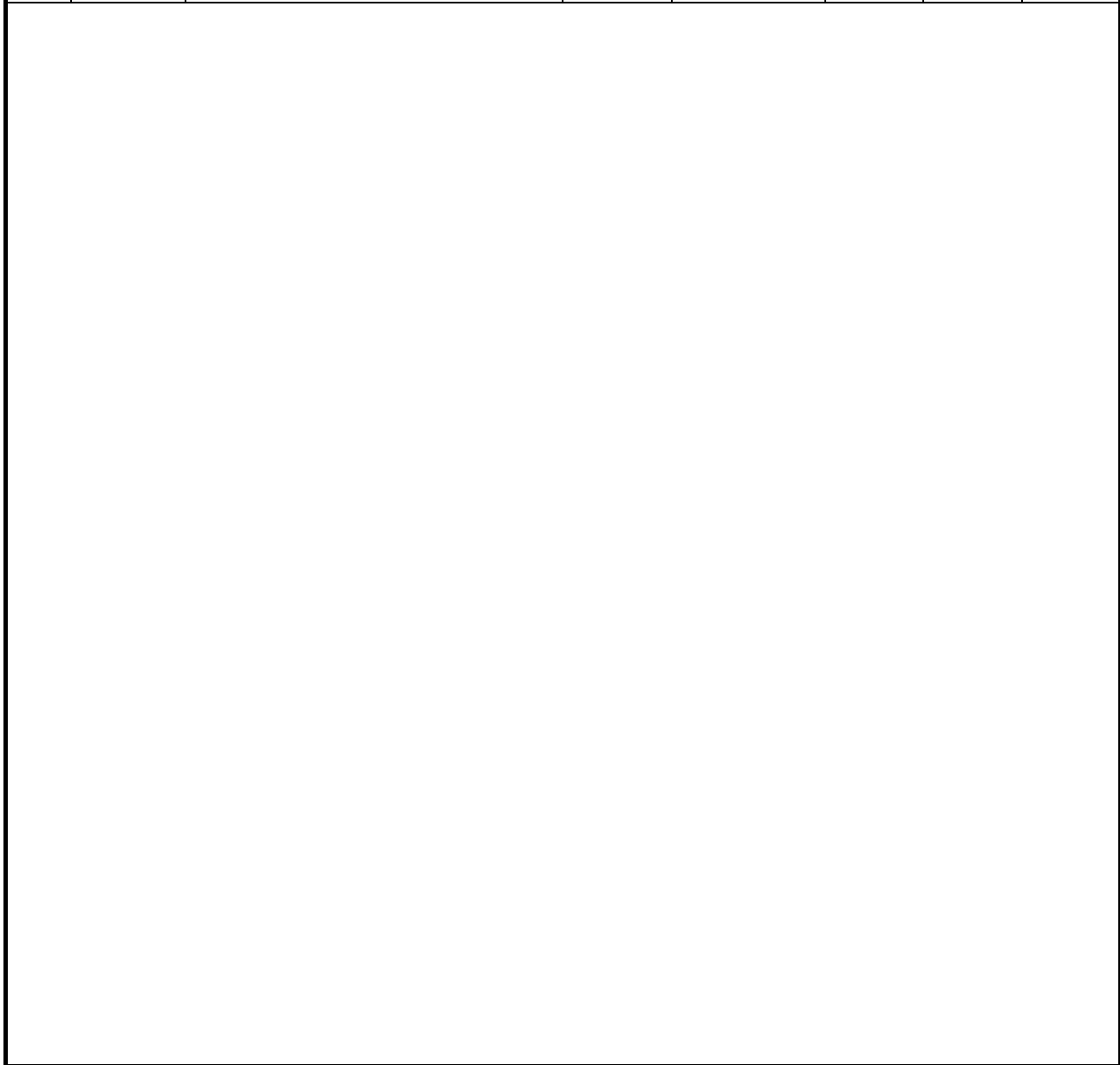

Foreword

Thank you for choosing Toyo VF66B inverter product.

This description is a communications protocol description of option substrate OPCN66-Z for VF66 inverters. In order to use the communication function of OPCN66-Z correctly, please carefully read this manual prior to using the OPCN66-Z.

This description explains OPCN-1 communication function of OPCN66-Z. Refer to a "[OPCN66-Z instructions manual](#)" for the terminal block function, the wiring method, a setup of a switch of an OPCN66-Z board, and a setup by the side of VF66B inverter .

In order to accommodate the many special functions to a wide variety of applications in addition to the basic inverter functions, please thoroughly read the VF66B inverter manual as well as any other applicable specialized instruction manuals.

The communication specification of OPCN66-Z is proportionate to OPCN-1 communications-standard JIS B 3511:1999 (JEM-F 3008:1999) which JIS (Japanese Standards Association) enacted. The term on the OPCN-1 communication in this description is proportionate to JIS B 3511:1999 (JEM-F 3008:1999).

Please read before use

For Safety

Before installing, operating, maintaining and inspecting OPCN66-Z option, please read this manual and all other appendices thoroughly in order to get familiarize with the feature of this option, safety information and correct handling. For safe operation, be sure to also thoroughly read the VF66B Inverter operating manual.

In this instruction manual, the safety instructions are classified in to two levels: DANGER and CAUTION.



Indicates a hazardous situation which may result in death or serious injury if it is handled improperly.



Indicates a hazardous situation which may result in moderate or minor injury or only in property damage if it is handled improperly. However, such a situation may lead to serious consequences depending on circumstances.

CAUTION [Installation]

- Do not use optional circuit board if you discover damage or deformation during unpacking. Doing so may cause optional circuit board failure or malfunction.
- Do not place any flammable materials near the optional circuit board. Doing so may cause a fire.
- Do not allow the optional circuit board to drop, fall over or sustain severe impacts. Doing so may cause optional circuit board failure or damage.
- Do not install or operate the optional circuit board if it is damaged or has any of its parts missing. Doing so may lead to personal injury.

DANGER [Wiring]

- Before wiring, make sure the power is OFF. Failure to do so may cause an electric shock or fire.
- Wait more than 10 minutes after turning the power OFF before opening the unit case lid. Failure to do so may cause an electric shock or fire.
- Make sure that the unit is correctly earthed. Failure to do so may cause an electric shock or fire.
- Wiring must be done by skilled technicians. Failure to do so may cause an electric shock or fire.
- Wire the unit after it is installed. Failure to do so may cause an electric shock or fire.

CAUTION [Wiring]

- Make sure that communication cables and connectors are properly installed and locked in place. Failure to do so may cause optional circuit board failure or malfunction.

DANGER [Operation]

- Turn the power ON after fitting the inverter front cover.
Do not remove the cover while the power is ON.
Doing so may cause an electric shock.
- Do not operate any switch with wet hands.
Doing so may cause an electric shock.
- Do not touch the inverter terminals while the power is ON, even if the inverter is in the idle state.
Doing so may cause an electric shock.
- If the alarm is reset while the operation signal kept input, the inverter will suddenly restart. Reset the alarm after making sure that the operation signal is OFF.
Failure to do so may lead to personal injury.
- The inverter can be set to operate in a wide range of speed. Operate the inverter after sufficiently checking the allowable range of the motor and equipment.
Failure to do so may cause personal injury, equipment failure or damage.

CAUTION [Operation]

- The inverter radiating fin and the radiating resistance are hot. Do not touch them.
Failure to follow this warning may cause burns.

DANGER [Maintenance, inspection and parts replacement]

- Always turn the power OFF before inspecting the inverter.
Failure to do so may cause an electric shock, personal injury or fire.
- Unauthorized persons shall not perform maintenance, inspection or parts replacement.
Use insulated tools for maintenance and inspection.
Failure to do so may cause electric shock or personal injury.

DANGER [Other]

- Never modify the unit.
Doing so may cause electric shock or personal injury.

CAUTION [General precautions]

Some illustrations given in this manual show the inverter from which the covers or safety shields have been removed to illustrate the details. Before operating the inverter, reinstall the covers and shields to their original positions and the inverter according to this manual.
These safety precautions and specifications stated in this manual are subject to change without notice.

Table of contents

Please read before use	3
For Safety	3
Chapter 1 Functional outline	6
Chapter 2 Basic Specification	7
2. 1 OPCN-1 Communication Terminal Specifications	7
2. 2 OPCN-1 Communication Specifications	7
2. 3 Communication mode	8
2. 4 Other	8
Chapter 3 Communication function explanation	9
3. 1 Setup of initial setting service	10
3. 2 The function using input/output service	10
3. 3 The function using data write-in service and data read-out service	21
3. 4 Function using simultaneous transmitting service	32
3. 5 Function using reset service	32

Chapter 1 Functional outline

OPCN66-Z is used equipping the connector of the PC board (VFC66-Z) in a VF66B inverter. The function of OPCN66-Z is equipped with an analog input/output function, multifunctional input/output function, and PG input/output function other than the communication function of an OPCN-1 slave station.

OPCN-1 is the standard specification of FA network of the device level which Japan Electrical Manufacturers' Association (JEMA) enacted, and it realizes the data communication network corresponding to a multi vendor. The communication specification of OPCN66-Z is proportionate to JIS (Japanese Standards Association) standard JIS B 3511:1999 (JEM-F 3008:1999).

By OPCN-1 communication function of OPCN66-Z, operation instructions, speed instructions, torque instructions, etc. are inputted into a VF66B inverter, or a monitor can do the operational status and the protection state of an inverter, current, voltage, etc. Moreover, the setting data of an inverter read-out/rewrites and read-out of trace back data, read-out of a protection history, and read-out of monitor data can be performed. Refer to a "OPCN66-Z communications protocol description" for OPCN-1 communication function. Moreover, it can be used as an input/output signal of the built-in PLC function of VF66B inverter. Refer to the description of VF66 PCTool for a built-in PLC function.

In order to reduce an environmental impact, OPCN66-Z is designed so that the content of a lead, mercury, cadmium, hexavalent chrome, PBB, and PBDE may be based on the RoHS instructions which EU defined.

CAUTION [Safety precautions]

Carefully read the instruction manual before use, and use the inverter correctly.

Our inverter and optional circuit board are not designed or manufactured for the purpose of use in life-support machines or systems.

If you intend to use the product stated in this document for special purposes, such as passenger cars, medical devices, aerospace devices, nuclear energy controls and submarine relaying machines or systems, consult our sales department.

This product is manufactured under strict quality control. However, if it is used in critical equipment in which inverter and optional circuit board failure may result in death or serious damage, provide safeguard to avoid serious accidents.

If you wish to use this inverter with loads other than three-phase AC traction, please contact us.

To use this product, electrical work is necessary. The electrical work must be done by qualified expert.

Chapter 2 Basic Specification

2. 1 OPCN-1 Communication Terminal Specifications

Table 2.1 Communication Terminal Specification

OPCN66-Z Terminal TBI	Terminal No.	Use	Description
	A	Communication Signal Terminal	<ul style="list-style-type: none"> ·OPCN-1 communication terminal ·Signal polarity of RS-485 (ISO/IEC8482)
	B		
	SG (2 terminals)	Communication Earth Terminal	·RS-485(ISO/IEC8482)Signal line data earth terminal
	FG	Protective Earth Terminal	·FG terminal is used when grounding all the station
	OPCN-1 Communication		

2. 2 OPCN-1 Communication Specifications

Table 2.2 OPCN-1 Communication Specification

Item	Specification																
Communication protocol	In conformity to JIS B 3511 (JEM-F3008)																
Applicable class of OPCN-1	TYPE-S521																
Electrical characteristics of physical layer	In conformity to RS-485 <ul style="list-style-type: none"> · +5V which insulated the power supply from the printed circuit board for inverter control through the built-in DC/DC converter is supplied. 																
Objective devices of communication	Devices having specification of master station of OPCN-1 in addition to our uGPCsx, uGPCH																
Type of connection	Bus type (Multi-drop system)																
Transmission speed and transmission distance	To be set by built-in console of VF66B Inverter unit 125kpbs - 1000m or less 250kpbs - 800m or less 500kpbs - 480m or less 1Mbps - 240m or less																
Transmission procedure	Half duplex transmission																
Synchronization system	Frame synchronization																
Modulation system	Base band system																
Encoding system	NRZI (Non Return to Zero Inverted)																
Connection, wiring system	Terminal block (5 poles), 2 wires or 3 wires type																
Connection cable	Twisted pair cable with shield (CO-SPEV-SB(A)2Px0.5 is recommendable)																
Number of connection station	1~31 stations as slave station against master station of 1 unit																
Setting of station number	Setting by built-in rotary switch of OPCN66-Z PCB																
Communication control system	Polling/selecting system																
Error check system	16 bits FCS (Frame check sequence) by a Cyclic Redundancy Check (CRC-CCITT)																
Network service	<table border="1" style="width: 100%; border-collapse: collapse;"> <tr><td>Initial setting service</td><td style="text-align: center;">○</td></tr> <tr><td>Input/output service</td><td style="text-align: center;">○</td></tr> <tr><td>Data readout service</td><td style="text-align: center;">○</td></tr> <tr><td>Data writing service</td><td style="text-align: center;">○</td></tr> <tr><td>Reset service</td><td style="text-align: center;">○</td></tr> <tr><td>Simultaneous communication all together</td><td style="text-align: center;">○</td></tr> <tr><td>Message reading service</td><td style="text-align: center;">×</td></tr> <tr><td>Messgae writing service</td><td style="text-align: center;">×</td></tr> </table>	Initial setting service	○	Input/output service	○	Data readout service	○	Data writing service	○	Reset service	○	Simultaneous communication all together	○	Message reading service	×	Messgae writing service	×
Initial setting service	○																
Input/output service	○																
Data readout service	○																
Data writing service	○																
Reset service	○																
Simultaneous communication all together	○																
Message reading service	×																
Messgae writing service	×																

2. 3 Communication mode

The communication mode of OPCN66-Z is with the "conformity mode" according to JIS (Japanese Standards Association) standard JIS B 3511:1999 (JEM-F 3008:1999), "The mode in which it is not based" whose communication with the master station of the original communication specification of our company sold before this standard establishment is attained can be chosen. (It corresponds to each "attestation mode" and "the mode in which it does not attest" of the conventional model OPCN64 or RSH64 of our company.)

Table 2.3 Correspondence with the conventional communication mode

	Communication specification based on a standard	Original communication specification of our company
OPCN66-Z	Conformity mode	Mode in which it is not based
Conventional model	Attestation mode	Mode in which it does not attest

The initial state at the time of shipment is in conformity mode. Usually, it is not necessary to change this switch.

When it is necessary to set it as the mode in which it is not based, please turn ON SW3 on an OPCN66-Z board.

※Change of sw3 is performed by certainly turning off the inverter.

2. 4 Other

Please refer to a "[OPCN66-Z instructions manual](#)" for specifications, such as other terminal stands.



DANGER [Wiring]

- Before wiring, make sure the power is OFF.
Failure to do so may cause an electric shock or a fire.



CAUTION [Wiring]

- G terminal and G2 terminal are not connected to a grounding by any means.
Doing so may cause equipment failure or damage.
- Never connect or allow contact between the PS and G terminals.
Doing so may cause equipment failure or damage.



CAUTION [Change of sw3]

- Change of sw3 is performed by certainly turning off the inverter.
Failure to do so may cause an electric shock, personal injury, equipment failure or malfunction.

Chapter 3 Communication function explanation

By OPCN-1 communication function of OPCN66-Z, operation instructions, speed instructions, torque instructions, etc. are inputted into a VF66B inverter, or a monitor can do the operational status and the protection state of an inverter, current, voltage, etc. Moreover, the setting data of an inverter read-out/rewrites and read-out of trace back data, read-out of a protection history, and read-out of monitor data can be performed. Moreover, it can be used as an input/output signal of the built-in PLC function of VF66B inverter. Refer to the description of VF66 PCTool for a built-in PLC function.

Refer to a "OPCN66-Z instructions manual" for the connection method of the OPCN-1 transmission line to the terminal stand of an OPCN66-Z board.

In order to communicate with an OPCN-1 master station, it is necessary to set the setting parameter of the main part of VF66 inverter shown in the following table.

Also refer to a "OPCN66-Z instructions manual", the instructions manual of the main part of VF66 inverter, and the instructions manual of the master office to be used collectively.

The direction of the OPCN-1 communication in this chapter shows the direction where an "input" is inputted into a master station from OPCN66-Z, and an "output" shows the direction outputted to OPCN66-Z from a master station. In the explanation about a built-in PLC function and a multifunctional input/output function, it is not applied.

Table 3.1 OPCN-1 communication-related setup

Console Display	Items	Item Selection	Default Data	Rewrites during Operation																														
J-00	Digital communication option selection	0: OFF 1: OPCN66-Z 2 to 7: Other options are set up at the time of use.	0	×																														
J-02	OPCN66-Z option baud rate	0: 125kbps 1: 250kbps 2: 500kbps 3: 1Mbps 4: (For factory adjustment) ²	3	×																														
J-04	OPCN66-Z option input	3 to 19	14	×																														
J-05	OPCN66-Z option output	2 to 12	6	×																														
J-07	ASYC66-Z/OPCN66-Z transmission selection/CC66-Z version selection	<p>The time from the end of reception to a transmitting start can be set up as shown in the following table. However, it is prescribed to 200 μs or more by JIS B 3511:1999 (JEM-F 3008:1999). Usually, please set it as 200 μs.</p> <table border="1"> <thead> <tr> <th rowspan="2"></th> <th colspan="4">Transmission speed (bps)</th> </tr> <tr> <th>125k</th> <th>250k</th> <th>500k</th> <th>1M</th> </tr> </thead> <tbody> <tr> <td rowspan="4">J-07</td> <td>0 to 3</td> <td>200 μs</td> <td>200 μs</td> <td>200 μs</td> <td>200 μs</td> </tr> <tr> <td>4</td> <td>200 μs</td> <td>150 μs</td> <td>150 μs</td> <td>150 μs</td> </tr> <tr> <td>5</td> <td>200 μs</td> <td>100 μs</td> <td>100 μs</td> <td>100 μs</td> </tr> <tr> <td>6</td> <td>200 μs</td> <td>100 μs</td> <td>50 μs</td> <td>50 μs</td> </tr> </tbody> </table>		Transmission speed (bps)				125k	250k	500k	1M	J-07	0 to 3	200 μs	200 μs	200 μs	200 μs	4	200 μs	150 μs	150 μs	150 μs	5	200 μs	100 μs	100 μs	100 μs	6	200 μs	100 μs	50 μs	50 μs	0	×
	Transmission speed (bps)																																	
	125k	250k	500k	1M																														
J-07	0 to 3	200 μs	200 μs	200 μs	200 μs																													
	4	200 μs	150 μs	150 μs	150 μs																													
	5	200 μs	100 μs	100 μs	100 μs																													
	6	200 μs	100 μs	50 μs	50 μs																													

*1: When these setup is changed, please once turn OFF the power supply of an inverter and switch on a power supply again.

*2: J-02=4 is for factory adjustment. Under normal conditions, please stay on the factory setting.

3. 1 Setup of initial setting service

When specifying I/O arrangement information by stypeM of initial setting demand SDU (service data unit) from master station to OPCN66-Z, a setup of the same n_io_arrM and io_arrM of SDU is coincided with the setup of J-04 and J-05 of the VF66B inverter setting parameter shown in table3.1 of a front page. When a setup is not coincidence, the RESULT code "initialization directions refusal" is replied as a processing result of initial setting service of OPCN66-Z. Moreover, when not specifying I/O arrangement information by stypeM, the number of input words and the number of output words of input/output service apply a setup of J-04 and J-05, respectively.

3. 2 The function using input/output service

By input/output service of OPCN66-Z, transmission of a operation command, reverse command, speed command, torque command, and transmission of a multifunctional input signals are made to a VF66B inverter from master station, and monitors, and a monitor can do operational status, a protection state, current, voltage, etc. of an inverter. Moreover, input/output service of OPCN66-Z can be used as an input-and-output signal of the built-in PLC function of VF66 inverter. Refer to the description of VF66 PCTool for a built-in PLC function.

Input/output service of OPCN66-Z supports only the **asynchronous method** .

To the number of input words and the number of output words of input/output service, a setup of J-04 and J-05 is applied, respectively.

In the input/output demand SDU which a master station transmits, a setup of len (L), len (H), iosizeM (L), and iosizeM (H) is united with a setup of J-05. Priority is given to a setup of J-05 when these setup does not suit a setup of J-05.

In the following explanation, the numerical value of the "address" part in Fig. 3.1 is an offset value from the head address (+13) of iodataM (output data) or iodataS (input data) in the input/output service SDU.

(1) Output Data

The output data (iodataM) of the input/output demand SDU transmitted from Master station is performed as follows.

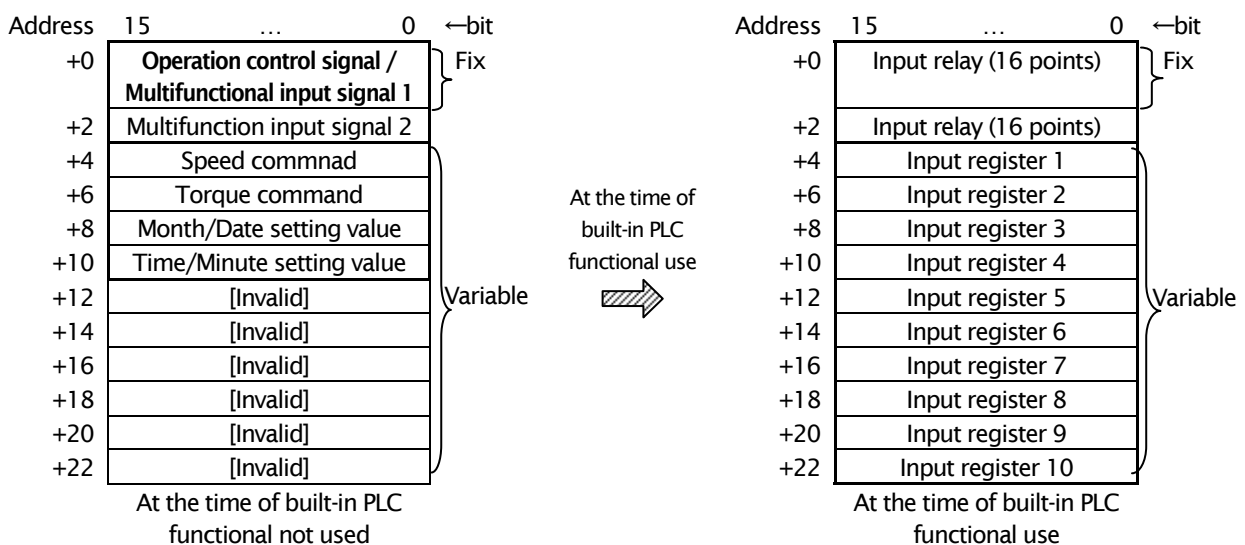

Figure 3.1 Composition of output data

Output data can use a built-in PLC function as an input to a built-in PLC function at the time of use. About a setup which is use or not used of a built-in PLC function as shown in the following table, it can set up with the setting parameter (i area) of the main part of a VF66B inverter. For details, refer to the instructions manual of the main part of a VF66B inverter. Refer to the description of VF66 PCTool for a built-in PLC function.

Table 3.2 Selection of built-in PLC functional use

Console Display	Items	Item Selection	Default Data	Rewrites during Operation
i-00	PLCL function usage selection	OFF (not use) ON (use)	OFF	×
i-01	PLCH function usage selection	0: OFF (not use) 1: PLCH ON 2: PLCH ON (speed command input = PLCH output)	0	×

The length of output data can be considered as fixation 2 words from a head, and it can change the 3-12th word. Please coincide the total number of words with a setup of the setting parameter J-05 of VF66B inverter. The total number of words is coincided with a setup of the setting parameter J-05 of a VF66B inverter.

When not using the built-in PLC function of a VF66B inverter, it is ignored after the 7th word.

When using the built-in PLC function of a VF66B inverter, each bit (the 1st word and the 2nd word) can be used as an input relay to a built-in PLC function. Moreover, when using a built-in PLC function, the 3-12th word is an input register to a built-in PLC function.

Refer to the description of VF66 PCTool for a built-in PLC function.

※When using a PLCL function, each bit (the 1st and the 2nd word) does not function as an operation control signal and a multifunctional incoming signal. In such a case, create the sequence which operates an operation control signal by a built-in PLC function.

In order to validate the various instructions by the communication to a VF66B inverter, it is necessary to set correctly the inverter setting parameter shown in the following table. In order to validate a 1st word operation control signal, it is necessary to turn on forward operation terminal "ST-F" of terminal block TB1 of VF66B inverter control board VFC66-Z. For details, refer to the instructions manual of the main part of VF66B inverter.

Table 3.3 Setup of input place selection of various instructions

Console Display	Items	Item Selection	Default Data	Rewrites during Operation
b-09	Commanding place when coupled	0: Terminal block 1: Console (SET66-Z) 2: Digital communication option	1	×
b-10	Speed commanding place selection (*1)	0: Coupled 1: Analog input(1)[terminal block](AIN1) 2: Console (SET66-Z) 3: Digital communication option 4: Analog input(2)[terminal block for IO66-Z option or digital communication option] (AIN2) 5: (For extension option) ¹ 6: Analog input(3)[IO66-Z option terminalblock](AIN3) 7: Built-in PLC	0	×
b-11	Operation commanding place selection	0: Coupled 1: Terminal block 2: Console (SET66-Z) 3: Digital communication option	0	×
b-12	JOG commanding place selection	0: Coupled 1: Terminal block 2: Console (SET66-Z) 3: Digital communication option	0	×
i-07	Operation mode selection(*2)	0: Speed control (ASR) mode 1: Torque command -direction priority 2: Torque command + direction priority 3: Torque control (ATR) mode 4: Speed/torque control contact switch	0	×
i-08	Torque command input place selection(*2)	0: Analog input (1) [terminal block](AIN1) 1: Analog input (2) [IO66-Z option or digital communication option](AIN2) 2: Digital communication option 3: Built-in PLC output	1	×
J-14	Date/Time data selection from communication	0: without date/time data 1: with date/time data	0	×

(*1) When inverter mode is set as V/f mode, b-10 becomes "input place selection of frequency instructions."

(*2) When inverter mode is set as V/f mode, i-07 and i-08 cannot be set up.

• 1st word : Operation control signal / Multifunctional input signal 1

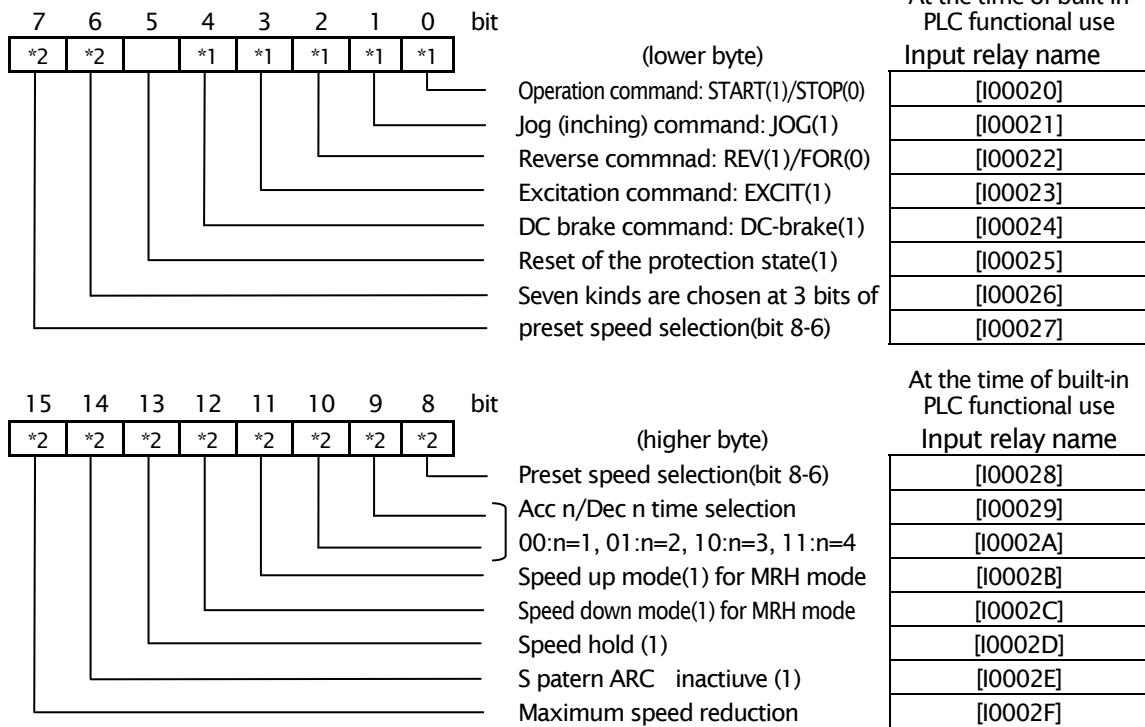

(*1) If the [ST-F] input of terminal block TB1 of a VFC66-Z board is turned ON, it will become effective about each instructions of bit 0-4. (When not using PLCL function)

(*2) Bit6~15 are multifunction input. (When not using PLCL function)

Figure 3.2 The bit configuration of the 1st word

• 2nd word : Multifunctional input signal 2

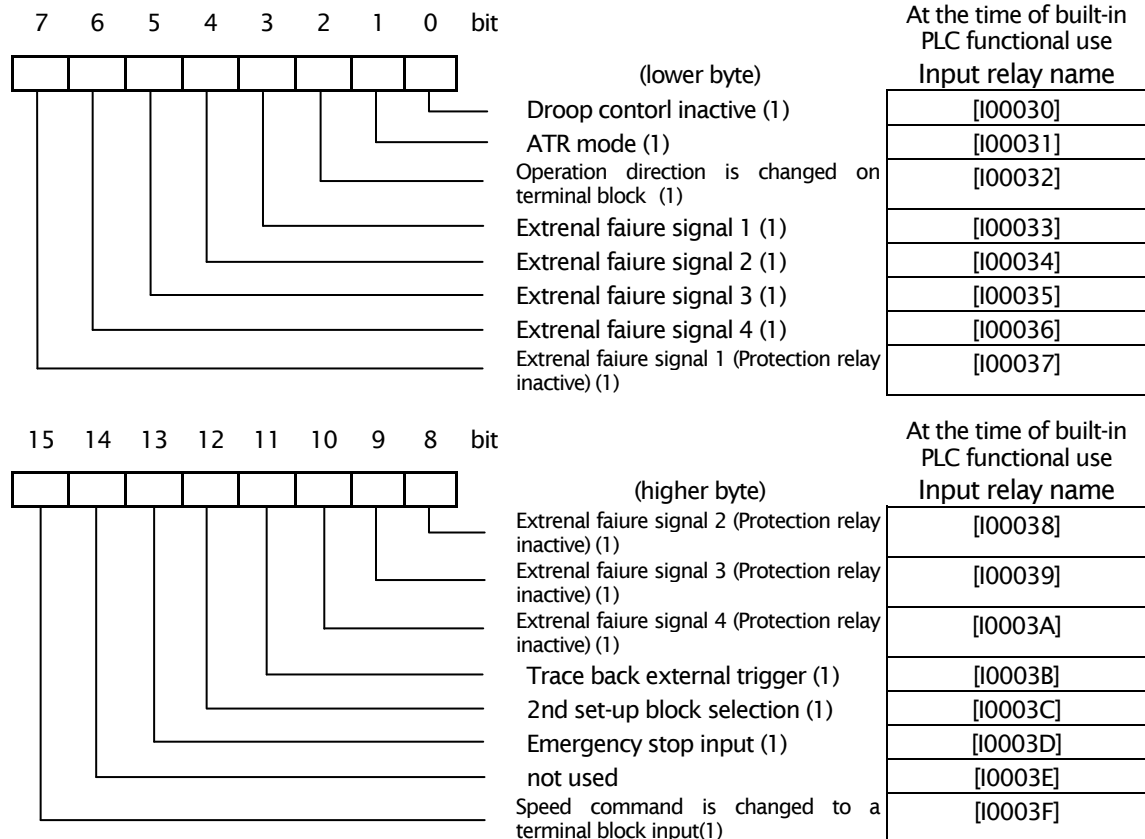

Figure 3.3 The bit configuration of the 2nd word

*In order to validate each instructions by the 0-4th bit of 1st word, a PLCL function was not used and it is necessary to turn on forward operation terminal "ST-F" of terminal block TB1 of VF66B inverter control board VFC66-Z. Furthermore, it is necessary to set the parameter of Table 3.3 correctly about operation command of bit 0 and jog command of bit 1.

*The 6-15 bits of 1st word and all bits of 2nd word is a multifunctional input signal by communication. In order to enable the multifunctional input function by communication, it is necessary to set the parameter of the multifunctional input place selection shown in the following table as a digital communication option, and to suppose un-using a PLCL function. For details, refer to the instructions manual of the main part of VF66B inverter.

Table 3.4 Setup of multifunctional input place selection

Console Display	Items	Item Selection	Default Data	Rewrites during Operation
c-00	Multifunction input place selection	0: Terminal block 1: Digital communication option	0	×

• The 3-6th word : Digital data for control “At the time of built-in PLC functional is not used”

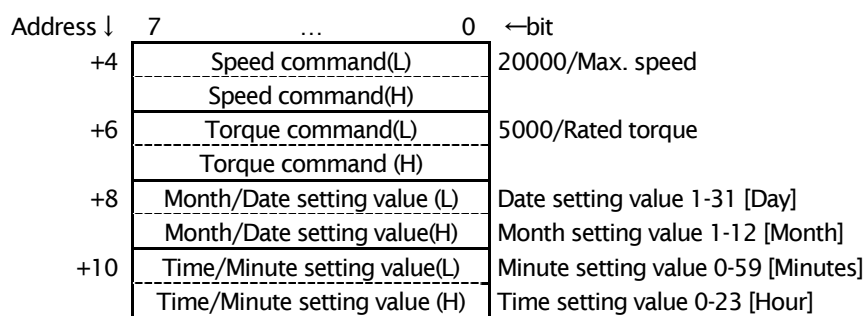

(*)In order to validate each instruction value and a preset value, it is necessary to set the setting parameter of Table 3.3 correctly so that each input place may serve as a digital-communications option.

Figure 3.4 Digital data for control (Built-in PLC function is not used)

The above figure is the data composition after the 3rd word in the case of using a built-in PLC function. **It is ignored after the 7th word.** In order to validate these instruction values and preset values, it is necessary to set correctly the inverter setting parameter shown in above Table 3.3. For details, refer to the instructions manual of the main part of a VF66B inverter.

• The 3-12th word : Input register “At the time of built-in PLC functional use”

Address ↓	7	...	0	←bit
+4	[i00010] (L)			Communication input register 1 /Speed command ^(*)
	[i00010] (H)			
+6	[i00011] (L)			Communication input register 2 /Torque command ^(*)
	[i00011] (H)			
+8	[i00012] (L)			Communication input register 3 /Month/Date setting value ^(*)
	[i00012] (H)			
+10	[i00013] (L)			Communication input register 4 /Time/Minute setting value ^(*)
	[i00013] (H)			
+12	[i00014] (L)			Communication input register 5
	[i00014] (H)			
+14	[i00015] (L)			Communication input register 6
	[i00015] (H)			
+16	[i00016] (L)			Communication input register 7
	[i00016] (H)			
+18	[i00017] (L)			Communication input register 8
	[i00017] (H)			
+20	[i00018] (L)			Communication input register 9
	[i00018] (H)			
+22	[i00019] (L)			Communication input register 10
	[i00019] (H)			

(*1) In order to validate each instruction value and a preset value, it is necessary to set the setting parameter of Table 3.3 correctly so that each input place may serve as a digital-communications option.

Figure 3.5 Input register (At the time of built-in PLC functional use)

The above figure is the data composition after the 3rd word in the case of using a built-in PLC function. The 3-6th word can be used together also as the instruction value or preset value shown in Fig. 3.4, if the setting parameter shown in Table 3.3 is set. Refer to the description of VF66 PCTool for a built-in PLC function.

(2) Input Data

The input data (iodataS) of the input/output demand SDU which OPCN66-Z transmits to a master office is shown in figure 3.6.

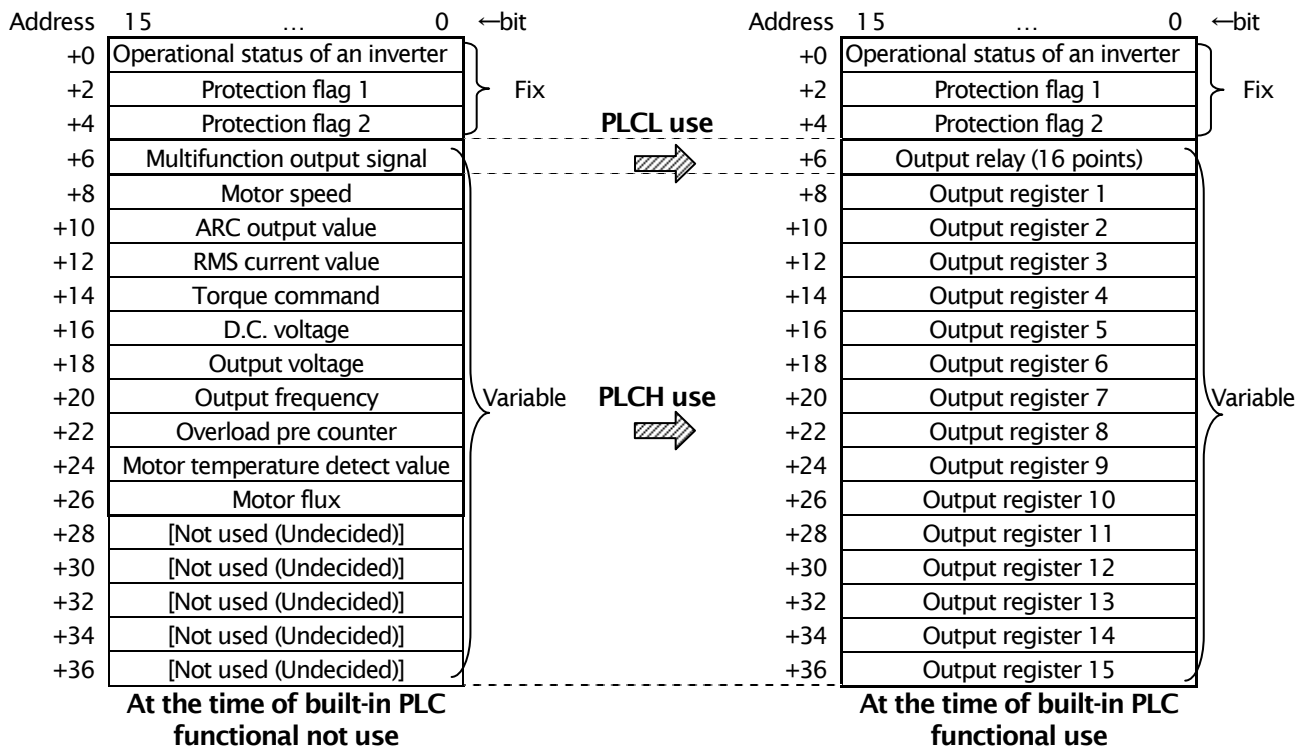

Figure 3.6 Configuration of input data

Data composition changes with use / un-using it of a built-in PLC function. About a setup which is use or not used of a built-in PLC function, and it sets up with the setting parameter (i area) of the main part of a VF66B inverter shown in Table 3.2. For details, refer to the instructions manual of the main part of VF66B inverter, and the description of VF66 PCTool.

3 words of the length of input data are fixation from a head, and it can change the 4-19th word. The total number of words is coincided with a setup of the setting parameter J-04 of a VF66B inverter.

When not using the built-in PLC function of a VF66B inverter, it is unfixed after the 15th word.

When using the PLCL function of a VF66B inverter, each bits of 4th word are set as the output relay of a built-in PLC function. Moreover, when using a PLCH function, it is set as the output register of a built-in PLC function the 5-19th word.

Refer to the description of VF66 PCTool for a built-in PLC function.

* In addition, since the internal data of the inverter contained in the same SDU as shown in the above figure is not the data simultaneously taken into a certain time, simultaneity is not between each data.

• 1st word : Operational status of an inverter

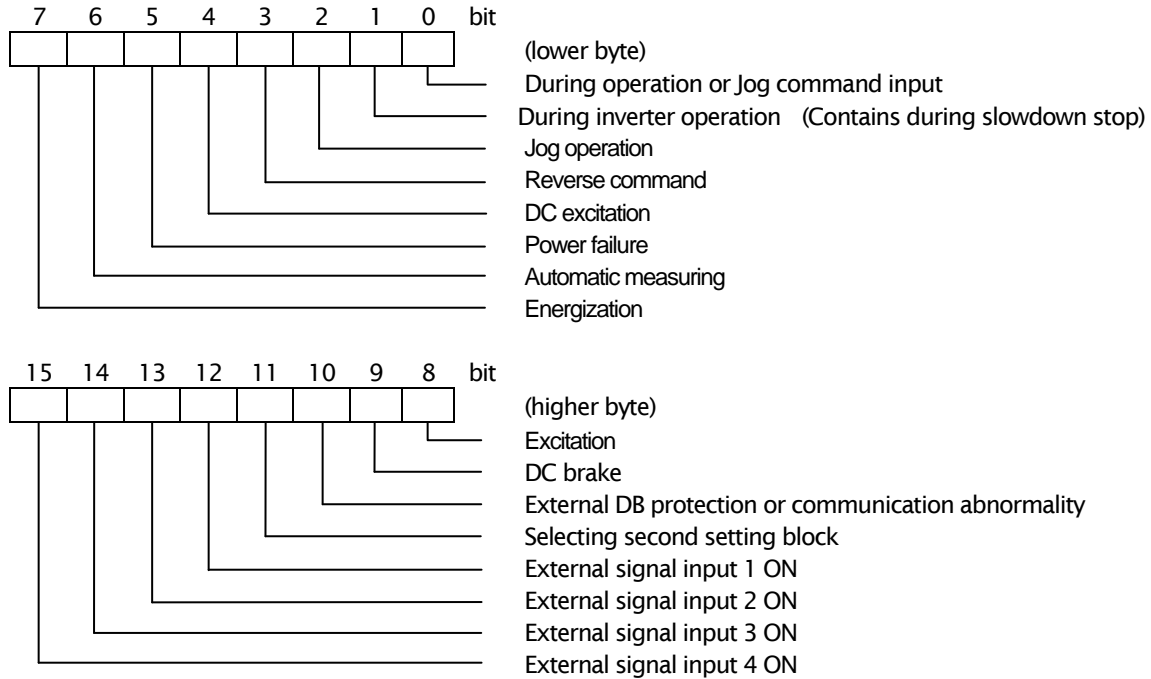

Figure 3.7 The bit configuration of the 1st word

• 2nd word : Protection flag 1

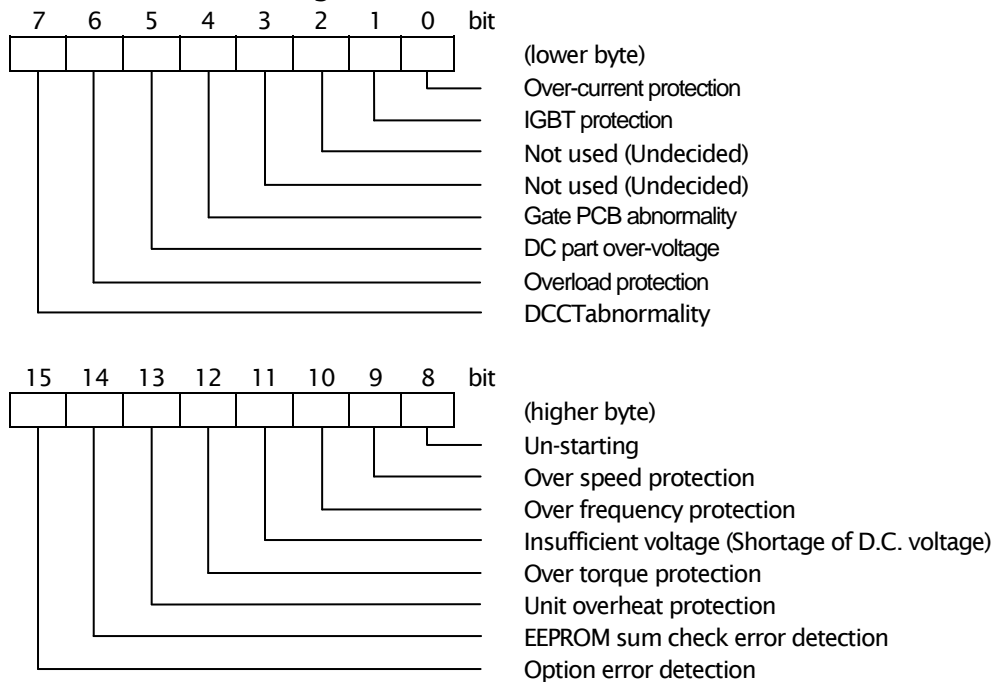

Figure 3.8 The bit configuration of the 2nd word

• 3rd word : Protection flag 2

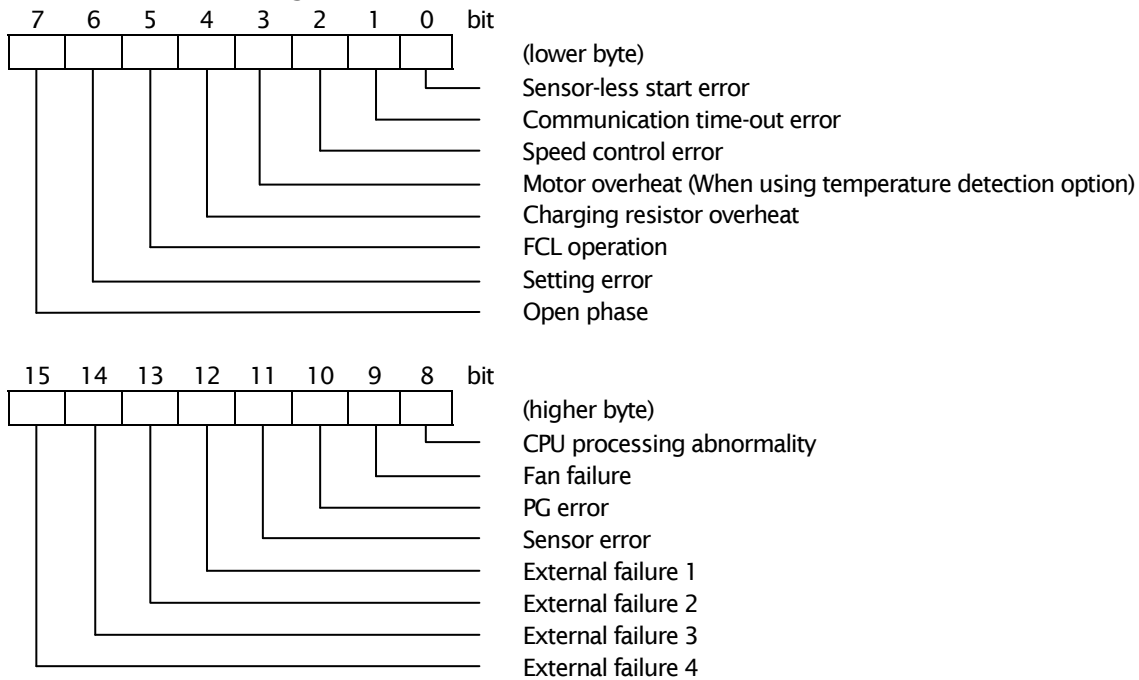
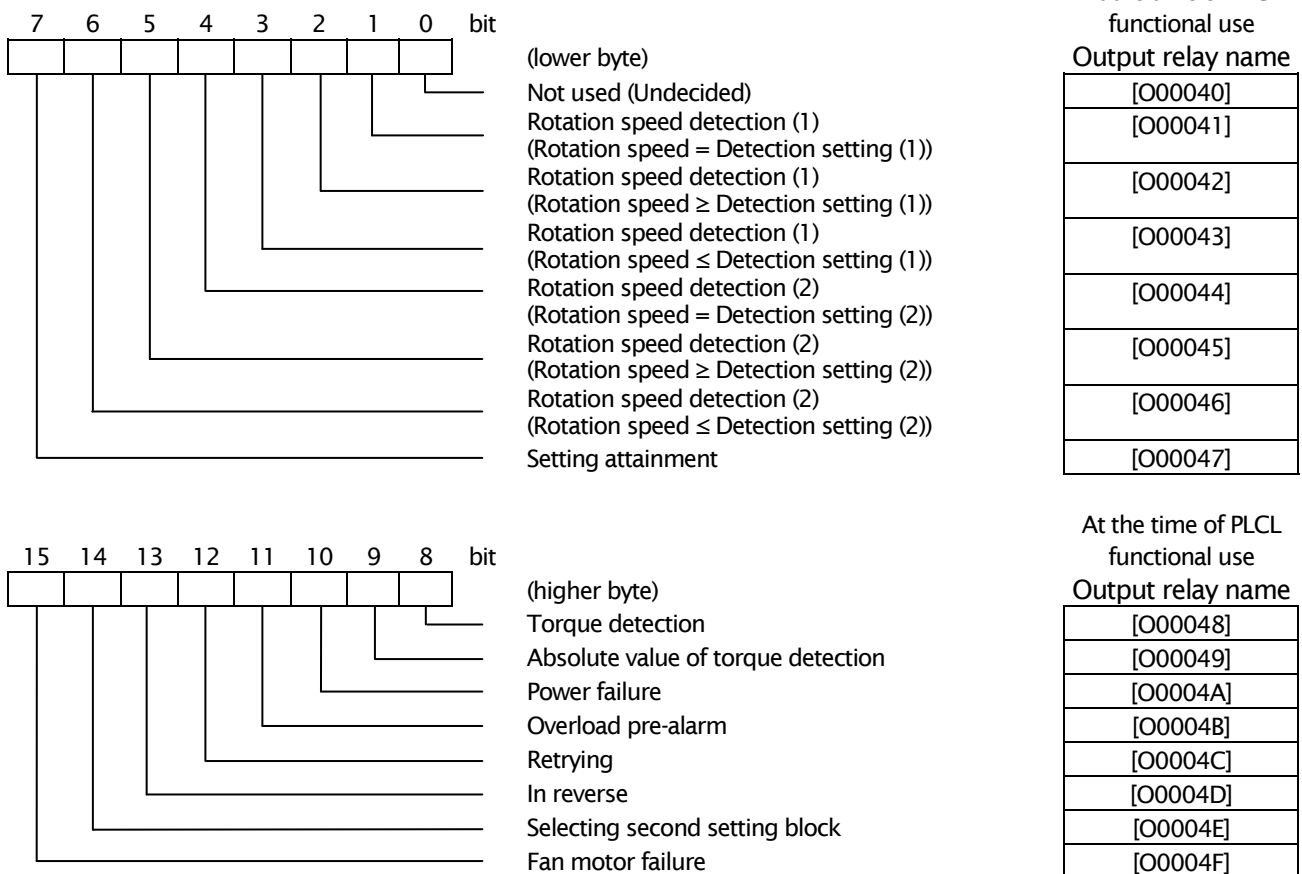

Figure 3.9 Bit configuration of 3rd word

• 4th word : State data of a multifunctional output



(*) Refer to the setting parameter (H area) of the instructions manual of the main part of VF66 inverter for the contents of the multifunctional output.

Figure 3.10 Bit configuration of 4th word

• The 5-14th word : Monitor output data [At the time of PLCH function is not used]

Address ↓	7	...	0	←bit
+8	Motor speed (L)			20000/Max value
	Motor speed (H)			At V/f mode, it is output frequency.
+10	ARC output value (L)			20000/Max.
	ARC output value (H)			
+12	RMS current value (L)			10000/Rated
	RMS current value (H)			
+14	Torque command (L)			5000/Rated
	Torque command (H)			At V/f mode, it is calculation torque.
+18	D.C. part voltage (L)			200V series : Vdc x10
	D.C. part voltage (H)			400V series : Vdc x5
+20	Output voltage (L)			200V series : Vo x20
	Output voltage (H)			400V series : Vo x10
+22	Output frequency (L)			20000/Max.
	Output frequency (H)			
+24	Overload pre-counter (L)			OL protection works by 10000.
	Overload pre-counter (H)			
+26	Motor temperature detect value (L)			10/1°C (At the time of temperature
	Motor temperature detect value (H)			detection option use)
+28	Motor flux (L)			1024/Rated
	Motor flux (H)			

Figure 3.11 Monitor output data (At the time of PLCH function is used)

* When not using a PLCH function, it becomes unfixed after the 15th word.

• The 5-19th word : Output register [At the time of PLCH function use]

Address ↓	7	...	0	←bit
+8	[o00010] (L)			Communication outputregister 1
	[o00010] (H)			
+10	[o00011] (L)			Communication outputregister 2
	[o00011] (H)			
+12	[o00012] (L)			Communication outputregister 3
	[o00012] (H)			
+14	[o00013] (L)			Communication outputregister 4
	[o00013] (H)			
+16	[o00014] (L)			Communication outputregister 5
	[o00014] (H)			
+18	[o00015] (L)			Communication outputregister 6
	[o00015] (H)			
+20	[o00016] (L)			Communication outputregister 7
	[o00016] (H)			
+22	[o00017] (L)			Communication outputregister 8
	[o00017] (H)			
+24	[o00018] (L)			Communication outputregister 9
	[o00018] (H)			
+26	[o00019] (L)			Communication outputregister 10
	[o00019] (H)			
+28	[o0001A] (L)			Communication outputregister 11
	[o0001A] (H)			
+30	[o0001B] (L)			Communication outputregister 12
	[o0001B] (H)			
+32	[o0001C] (L)			Communication outputregister 13
	[o0001C] (H)			
+34	[o0001D] (L)			Communication outputregister 14
	[o0001D] (H)			
+36	[o0001E] (L)			Communication outputregister 15
	[o0001E] (H)			

Figure 3.12 Output register (At the time of PLCH function is used)

The above figure is the data composition after the 5th word in the case of using a PLCH function. Refer to the description of VF66 PCTool for a built-in PLC function.

3. 3 The function using data write-in service and data read-out service

By combining data write-in service and data read-out service, OPCN66-Z can perform readout of the setting data, readout of trace back data, readout of a monitor, readout of a protection history, and rewriting of setting data of VF66B inverter.

In the following explanation, the value shown in the "address" part in a figure is offset from the head address (+10) of data in the data readout service SDU and the data write-in service SDU.

* Ask separately about the setting data number of a VF66B inverter.

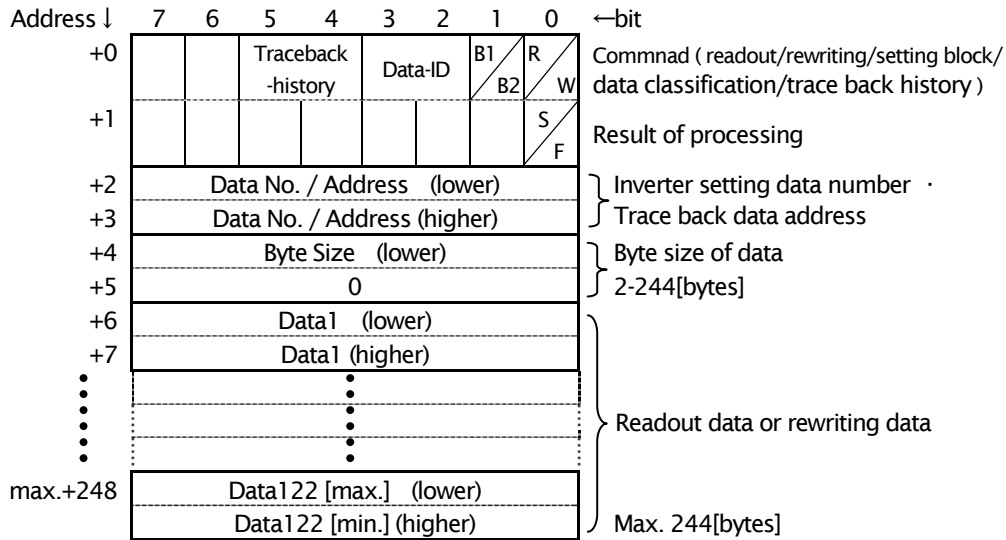

Figure 3.13 Data composition of data readout service SDU and data write-in service SDU

Table 3.5 1st word details

Bit	Contents	Setting item
0	R/W (Read/Write)	0: It sets up, when reading setting data, trace back data, monitor, protection history of an inverter. 1: It sets up, when rewriting the setting data of an inverter.
1	B1/B2 (Block1/Block2)	0: It sets up at the time of readout/rewriting of the inverter setting data of the 1st setting block. 1: It sets up at the time of readout/rewriting of the inverter setting data of the 2nd setting block.
2,3	Data-ID (data classification)	00: It sets up at the time of readout/rewriting of the inverter setting data. 01: It sets up, when reading a protection history. 10: It sets up, when reading a trace back data. 11: It sets up, when reading a monitor.
4,5	Traceback-history	00: It specifies, when reading the last (newest) trace back data. 01: It specifies, when reading the trace back data of 2 times ago. 10: It specifies, when reading the trace back data of 3 times ago. 11: It specifies, when reading the trace back data of 4 times ago (oldest).
6,7	Not used	Not used (Unfixed, when OPCN66-Z transmits)
8	S/F (Success/Fail)	It is a result of processing. OPCN66-Z sets and transmits at the time of data read-out service. 0: The normal end of processing is meant. 1: The abnormal end of processing is meant.
9-15	Not used	Not used (Unfixed, when OPCN66-Z transmits)

(1) Outline of a procedure

- 1) A master station transmits instructions to OPCN66-Z by data write-in demand, it directs data readout / rewrite, a data number, the byte size of data, and rewriting data (at the time of setting data rewriting) . Since all data sizes are 1 word (2 bytes), the byte size of data serves as even number. In the case of odd number, a part for 1 byte of the last data is disregarded.
- 2) OPCN66-Z replies the received data to a master office as it is as a data write-in response.
- 3) OPCN66-Z processes data between VFC66-Z according to instructions of 1), and sets a processing result to the data readout demand SDU. A S/F bit is set to the 1st word by the success or failure of processing.
- 4) By data read-out demand, master station transmits demand data, as OPCN66-Z transmits a processing result
- 5) OPCN66-Z replies the data created by 3) as a data read-out demand.

* The data which OPCN66-Z transmits with data readout service is only a result of the processing directed with data write-in service in advance. When not correctly directed by data write-in service, OPCN66-Z answers considering the status part between 7L level of 7 L_hd as "with no slave station transmitting data (data transceiver service 2)."

Below, readout and the rewriting procedure of setting data of various data are explained separately.

(2) Readout of setting data

The following procedures perform readout of the setting data of VF66B inverter.

- 1) Master station transmits the data write-in demand shown in figure 3.14 to OPCN66-Z, and directs readout of setting data, and the number of top setting data, and the total byte size of the data to read. Both of the setting data, 1st / 2nd setting block, can be read. Since all data sizes are 1 word (2 bytes), the byte size of data serves as even number. In the case of odd number, a part for 1 byte of the last data is disregarded. 122 words data can be read at the maximum at once. At this time, byte size directions of 2nd word are set to 244 [bytes].

* Ask separately about the setting data number of a VF66B inverter.

- 2) OPCN66-Z replies the received data to a master station as it is as a data write-in response.
- 3) By data readout demand, as a master office transmits a processing result to OPCN66-Z, it transmits demand data. The demand data at this time becomes the same as 1).
- 4) As a data readout demand, OPCN66-Z gives a S/F (success or failure of processing) bit to 1st word, and replies the setting data read from the inverter (figure 3.15). 122 words setting data is transmitted at the maximum at once.

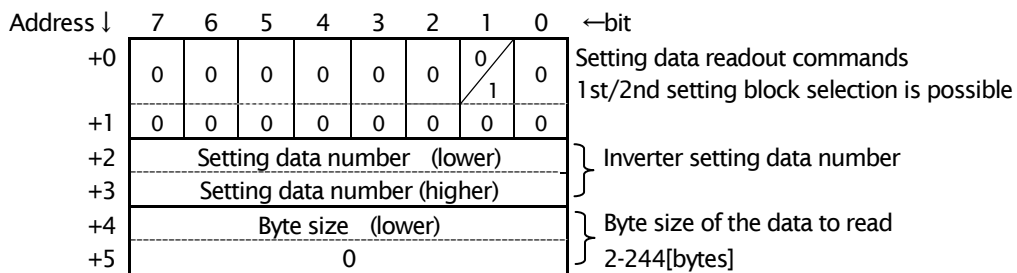

Figure 3.14 Data composition of the master station data writein demand SDU (setting data readout command)

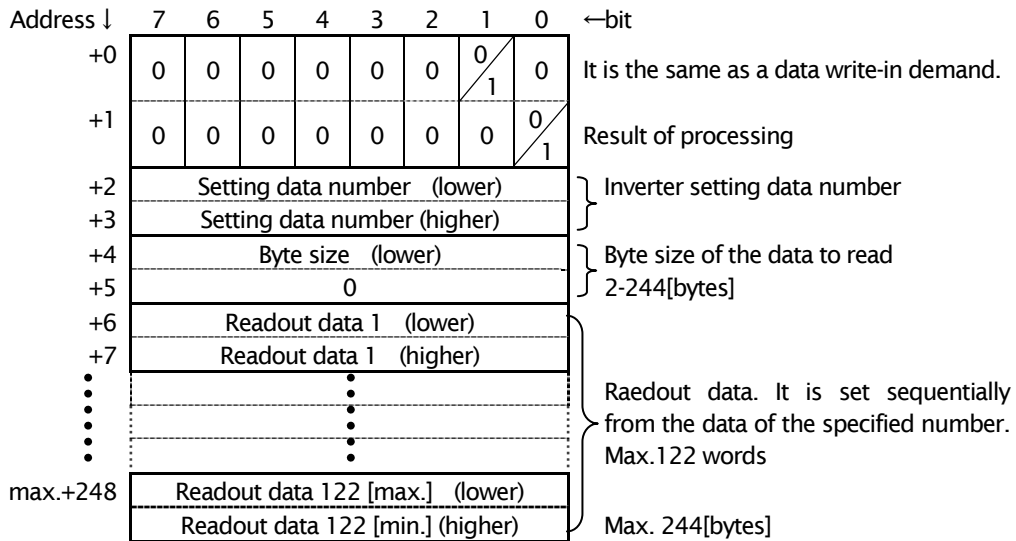

Figure 3.15 Data composition of the master station data readout check SDU (setting data readout result)

(3) Read-out of a protection history

The history of the past 6 times of the protection items which operated can be read.
 Readout of the protection history of a VF66B inverter is the following procedures.

- 1) A master station transmits the data write-in demand shown in figure 3.16 to OPCN66-Z, and directs readout of a protection history. 2nd word byte size directions are 12 [byte] (6 words) fixation.
- 2) OPCN66-Z replies the received data to a master station as it is as a data write-in response.
- 3) By data readout demand, as a master office transmits a processing result to OPCN66-Z, it transmits demand data. The demand data at this time becomes the same as 1).
- 4) As a data readout demand, OPCN66-Z gives a S/F (success or failure of processing) bit to 1st word, and replies the protection history data read from the inverter (figure 3.17). 6 words protection history data are transmitted sequentially from the newest history. The bit configuration of protection history data is shown in table 3.6, and the contents of the protection code are shown in table 3.7. The contents of the protection history are the same as that of the protection history of the monitor display of a SET66-Z console. Also refer to the instructions manual of the main part of VF66 inverter collectively.

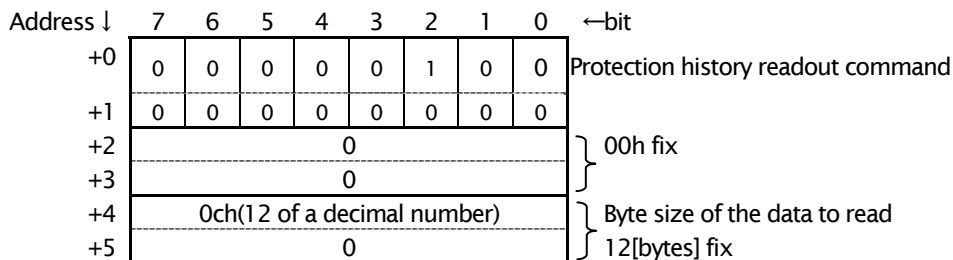

Figure 3.16 Data composition of the data write-in demand SDU (Protection history readout command)

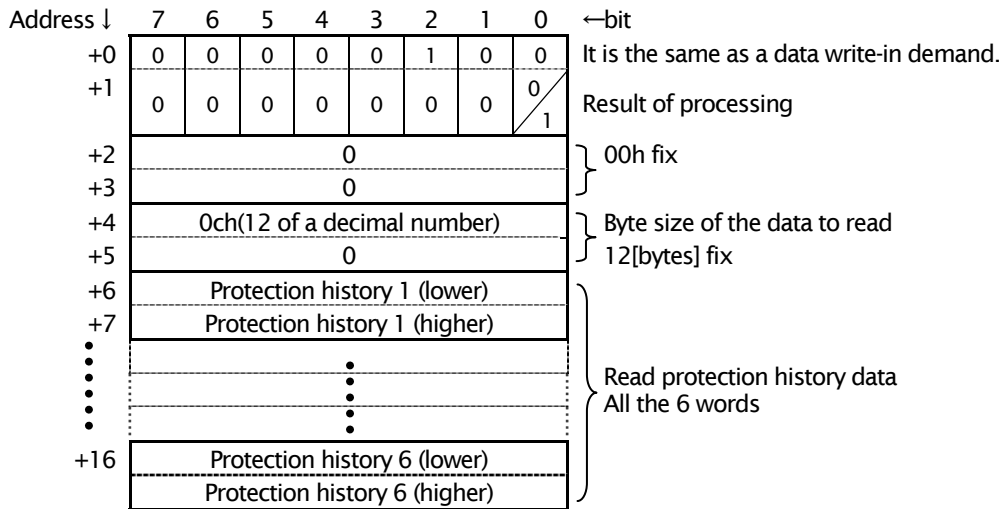

Figure 3.17 Data composition of the master station data readout check SDU (Protection history readout result)

Table 3.6 Protection History Data

Bit	Contents	Explanation of Contents
0 to 7	Protection code	Refer to Table 3.7
8, 9	Inverter mode	00: V/f mode 01: Induction motor vector mode 10: ED motor vector mode 11: Not used
10, 11	Not used (Undefined)	—
12	Setting block	0: First setting block 1: Second setting block
13 to 15	Not used (Undefined)	—

Table 3.7 Protection Codes

Protection Code	Protection Contents	Explanation of Protection Operation
1	Over-current protection	Protection of the instantaneous value of output current works by 3.58 or more times of an inverter amperage rating value.
2	IGBT protection	Protection works at the time of the over-current of IGBT, or a gate power supply fall.
3	Emergency stop A input contact is ON	In the multifunctional input set as the emergency stop A, an emergency stop works by ON.
4	Emergency stop B input contact is OFF	In the multifunctional input set as the emergency stop B, an emergency stop works by OFF.
5	Gate PCB abnormality	Protection detection by a GAC board. (only for models using GAC PCB)
6	DC part over-voltage	200V model: When D.C. part voltage exceeds 400V, protection works. 400V model: When D.C. part voltage exceeds 800V, protection works.
7	Overload protection	If an output current effective value operates for more than 1 minute with 150% of motor amperage rating values, overload protection will work.
8	Current sensor abnormality	Protection works by failure of a current sensor.
9	Un-starting	After operation or jog instruction input, even if 10 seconds pass, when operation is impossible, protection works.
10	Over-speed protection	When motor speed exceeds fault speed setting, protection works. (Induction motor vector mode / ED motor vector mode)
11	Over-frequency protection	When output frequency exceeds a fault frequency setup, protection works. (V/f mode)
12	Insufficient voltage (Power failure)	200V model: If D.C. voltage becomes less than 180V during operation, protection will work. 400V model: If D.C. voltage becomes less than 180V during operation, protection will work.
13	Over-torque protection	When over-torque protected operation is set as ON and it operates for more than 1 minute by 150% of rated torque, protection works. (Induction motor vector mode / ED motor vector mode)
14	Unit overheat	When the temperature of IGBT becomes beyond a predetermined value, protection works.
15	Storage memory abnormality	When the setting data memorized by the built-in memory cannot be acquired correctly, protection works.
16	Option error	If option substrate use is set as ON and an option substrate causes a defect of operation, protection will work.
17	Sensor-less start error	In sensor-less mode, when the phase detection at the time of starting goes wrong, protection works. (ED motor vector mode)
18	Communication time-out error	When a communication error (timeout) is caused between an option and a master at the time of the option use which performs network communication, protection works.
19	Speed control error	When rate control unusual detection is set as ON and the deviation of motor speed and an instruction value (rate control input) exceeds a preset value (console setup), protection works. (Induction motor vector mode / ED motor vector mode)
20	Motor overheat	When motor temperature exceeds 150 degrees C at the time of ON at the time of temperature detection option use in a motor overheating selection setup (F-06), protection works.
21	Charging resistor overheat	In a model of 7.5kW or less, when charge resistance is overheated, protection works.
22	FCL operation	When an instant current limit (FCL) continues for 10 seconds (near 0Hz 2 seconds) continuously, protection works.
23	Setting error	When it starts in the state where a setup of motor rating and a motor constant has abnormalities, protection works.
24	Open phase	When an output line is disconnected, protection works.
25	CPU processing abnormality	When CPU performs unusual processing due to the instant sag of 5V power supply for control, protection works.
26	Fan failure	When the fan in an inverter breaks down, protection works. (no protection stop).
27	PG error	- Even if a motor rotates above by two cycles by an electric phase, when there is no input of U, V, and W signal from PG, protection works. - When a motor is two or more revolutions in a machine phase and there is no input in Z signal of PG, protection works. (ED motor vector mode)
28	Sensor error	When there is no input of a current sensor or PG, protection works. (ED motor vector mode)
29	External failure 1	When the external failure 1 of a multifunctional input is inputted, protection works.
30	External failure 2	When the external failure 2 of a multifunctional input is inputted, protection works.
31	External failure 3	When the external failure 3 of a multifunctional input is inputted, protection works.
32	External failure 4	When the external failure 4 of a multifunctional input is inputted, protection works.

※Please also refer to the VF66B inverter manual.

※Protection codes 33 and above show GAC protection detection and is only for models using GAC. For more information, please refer to the supported VF66B inverter model manual.

(4) Trace back data readout

VF66B inverter memorizes the data of the current, voltage, etc., at the time of protected operation and contains the trace back function which reads afterwards and can be used for analysis. In order to use a trace back function effectively, it is necessary to set a setting parameter (F area) correctly in the main part of an inverter beforehand. For details, refer to the instructions manual of the main part of VF66 inverter.

Readout of the trace back data of a VF66B inverter is the following procedures.

- 1) Master station transmits the data write-in demand shown in figure 3.18 to OPCN66-Z, and directs readout of trace back data, and trace back data address, and the total byte size of the data to read. Since all data sizes are 1 word (2 bytes), the byte size of data serves as even number. In the case of odd number, a part for 1 byte of the last data is disregarded. Moreover, a trace back data address specifies even number. In the case of odd number, a part for 1 byte of the last address is disregarded. The history of trace back data can be specified to four in the bits 4 and 5 of 1st word. A setup of a trace back data history is shown in the following table.

Table 3.8 Trace-Back Data History Configuration

Bit5	Bit4	Trace-Back Data History
0	0	1 before (Newest)
0	1	2 before
1	0	3 before
1	1	4 before (Oldest)

Maximum of 100 words data can be read at once. At this time, byte size directions of 2nd word are set to 200 [bytes].

Correspondence with the channel and an address of trace back data is shown in Table 3.9, and the contents of data of each channel are shown in Table 3.10. However, ch1-ch12 differ from the contents shown in a table, when a setup of the inverter setting parameter F-15 to F-26 is not 0. For details, refer to the instructions manual of the main part of VF66 inverter.

- 2) OPCN66-Z replies the received data to a master station as it is as a data write-in response.
- 3) By data readout demand, as a master office transmits a processing result to OPCN66-Z, it transmits demand data. The demand data at this time becomes the same as 1).
- 4) As a data readout demand, OPCN66-Z gives a S/F (success or failure of processing) bit to 1st word, and replies the trace back data and 2 words trigger time information to read from the inverter (figure 3.19). Keep in mind that 4 bytes increases more than the byte size directed by the above 1). 100 words trace back data is transmitted at the maximum at once.

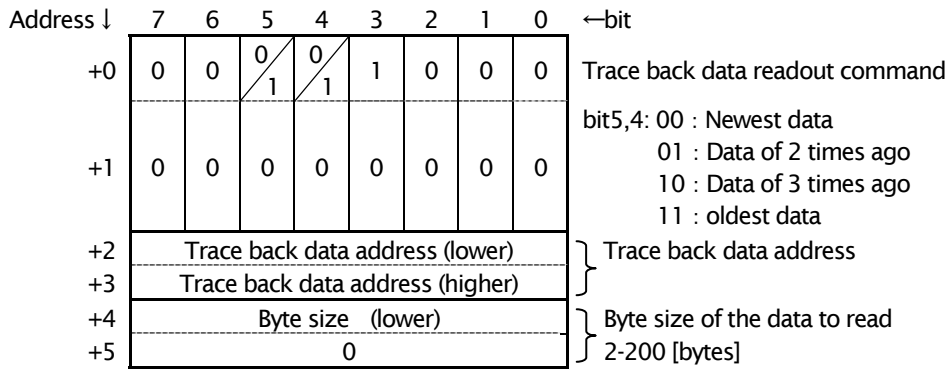

Figure 3.18 Data composition of the data write-in demand SDU (Trace back data readout command)

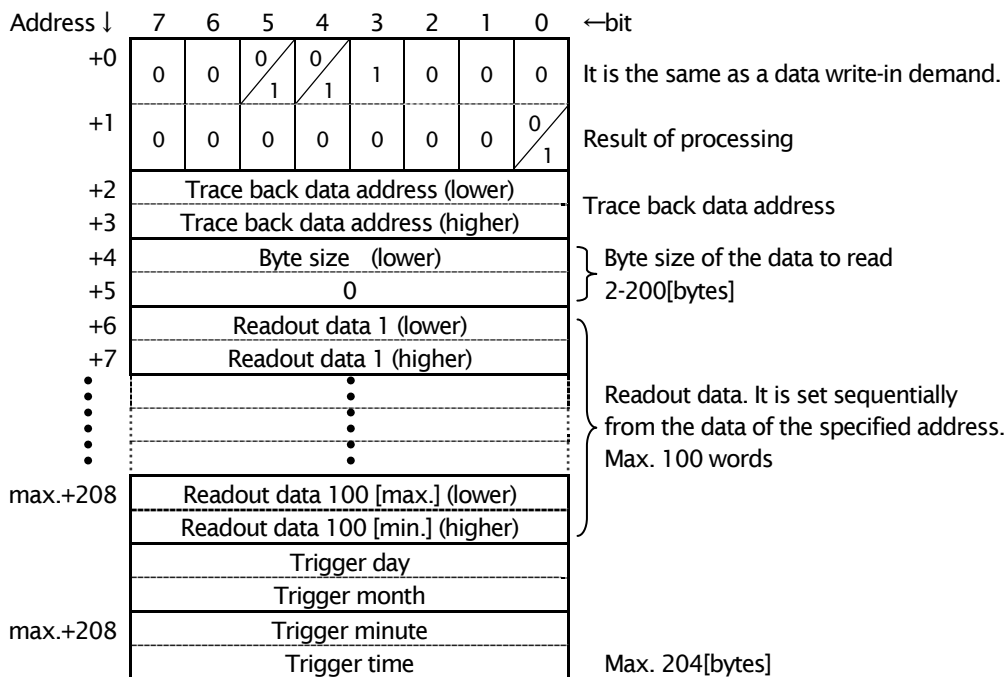

Figure 3.19 Data composition of the master station data readout check SDU (Protection history readout result)

Table 3.9 Trace back channel—Trace back address conversion table

ch	Trace-Back Data Address	ch	Trace-Back Data Address
0	0~199 (0000H~00C7H)	8	1600~1799 (0640H~0707H)
1	200~399 (00C8H~018FH)	9	1800~1999 (0708H~07CFH)
2	400~599 (0190H~0257H)	10	2000~2199 (07D0H~0897H)
3	600~799 (0258H~031FH)	11	2200~2399 (0898H~095FH)
4	800~999 (0320H~03E7H)	12	2400~2599 (0960H~0A27H)
5	1000~1199 (03E8H~04AFH)	13	2600~2799 (0A28H~0AEFH)
6	1200~1399 (04B0H~0577H)	14	2800~2999 (0AF0H~0BB7H)
7	1400~1599 (0578H~063FH)	15	3000~3199 (0BB8H~0C7FH)

Table 3.10 Trace-Back Data Contents (When F-15 to 26 are "0")

ch	V/f Mode		Induction Motor Vector Mode		ED Motor Vector Mode	
	Contents	Scale	Contents	Scale	Contents	Scale
0	U-phase current	2357/100%	U-phase current	2357/100%	U-phase current	2357/100%
1	V-phase current	2357/100%	V-phase current	2357/100%	V-phase current	2357/100%
2	W-phase current	2357/100%	W-phase current	2357/100%	W-phase current	2357/100%
3	D.C.voltege	10/V ⁽¹⁾	D.C.voltege	10/V ⁽¹⁾	D.C.voltege	10/V ⁽¹⁾
4	Output voltage	20/V ⁽²⁾	Output voltage	20/V ⁽²⁾	Output voltage	20/V ⁽²⁾
5	Motor speed	20000/Max	Motor speed	20000/Max	Motor speed	20000/Max
6	Not used	Undecided	Speed commnad	20000/Max	Speed command	20000/Max
7	Torque	5000/100%	Torque	5000/100%	Torque	5000/100%
8	Output frequency	20000/Max	Output frequency	20000/Max	Output frequency	20000/Max
9	Not used	Undecided	Slip frequency	20000/Max	d axis current	10000/100%
10	Not used	Undecided	Flux command	1024/100%	q axis current	10000/100%
11	Temperture	10/°C	Temperture	10/°C	d axis position	65536/360 degree
12	Protection flag (1) ⁽³⁾	Refer to figure 3.8	Protection flag (1) ⁽³⁾	Refer to figure 3.8	Protection flag (1) ⁽³⁾	Refer to figure 3.8
13	Protection flag (2) ⁽⁴⁾	Refer to figure 3.9	Protection flag (2) ⁽⁴⁾	Refer to figure 3.9	Protection flag (2) ⁽⁴⁾	Refer to figure 3.9
14	Status flag ⁽⁵⁾	Refer to table 3.11	Status flag ⁽⁵⁾	Refer to table 3.11	Status flag ⁽⁵⁾	Refer to table 3.11
15	Command flag ⁽⁶⁾	Refer to table 3.12	Command flag ⁽⁶⁾	Refer to table 3.12	Command flag ⁽⁶⁾	Refer to table 3.12

*1: The scale is 5/V in 400V system.

*2: The scale is 10/V in 400V system.

*3: The same as the contents shown in Table 3.8.

*4: The same as the contents shown in Table 3.9.

*5: The status flag is the same as the contents shown in Following table.

Table 3.11 Status Flags

Bit	Meaning	Bit	Meaning
0	Under normal operation or jog operation commnad input	8	Excitation
1	Under inverter operation (It contains also during slowdown stop operation.)	9	DC brake
2	Jog operation	10	Stronger flux when starting
3	Reverse command	11	End of program operation
4	DC excitation	12	Not used (Undefined)
5	Power failure	13	Reverse command state just before operation
6	Automatic measuring	14	Not used (Undefined)
7	Energization	15	High speed current limiting FCL in operation

*6: Commnad flag is the following table

Table 3.12 Command Flags

Bit	Meaning	Bit	Meaning
0	Normal operation command	8	DC excitation command
1	Jog operation command	9	0 speed maintenance command
2	Reverse command	10	Automatic measuring command
3	Excitation command	11	Emergency B-contact command
4	DC brake command	12	Not used (Undefined)
5	Reset command	13	Not used (Undefined)
6	Initial excitation command	14	Not used (Undefined)
7	Emergency stop command	15	Constant recalculation request

(5) Monitor Data Read-out

The monitor item displayed on the SET66-Z console of a VF66B inverter can be read.
Readout of the monitor data of a VF66B inverter is the following procedures.

- 1) Master station transmits the data write-in demand shown in figure 3.20 to OPCN66-Z, and directs readout of monitor data. Byte size directions of 2nd word are fixation in 50 [a byte] (25 words). OPCN66-Z replies the received data to a master station as it is as a data write-in response.
- 2) By data readout demand, as a master office transmits a processing result to OPCN66-Z, it transmits demand data. The demand data at this time becomes the same as 1).
- 3) As a data readout demand, OPCN66-Z gives a S/F (success or failure of processing) bit to 1st word, and replies monitor data (figure 3.19). 25 words monitor data is transmitted at once. The contents of monitor data are shown in Table 3.13. It is the same as that of the monitor item displayed on a console. For details, refer to the instructions manual of the main part of VF66 inverter.

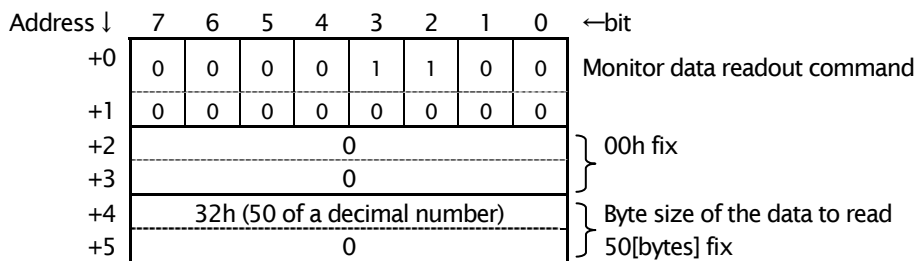

Figure 3.20 Data composition of the data write-in demand SDU (Monitor data readout command)

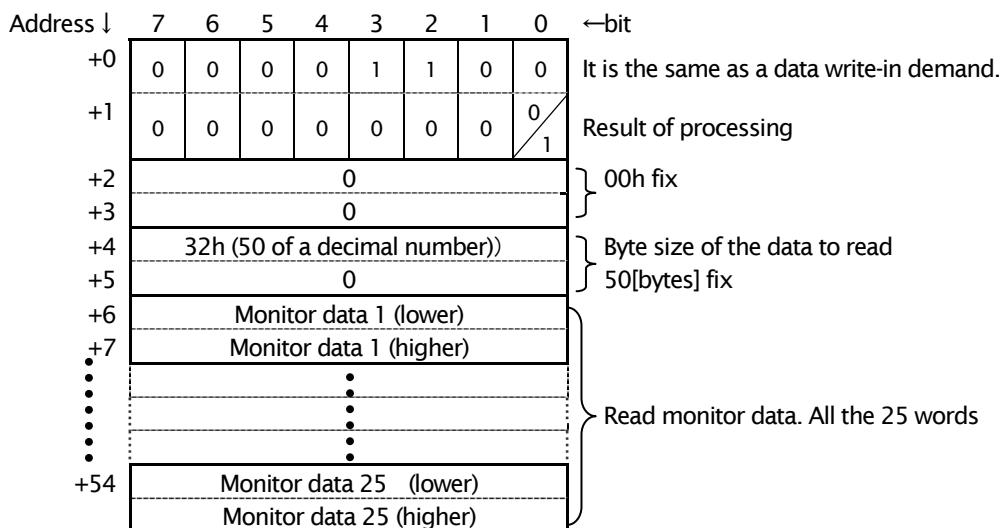

Figure 3.21 Data composition of the master station data readout check SDU (Monitor data readout result)

Table 3.13 Monitor Data

Number	V/f Mode		Induction Motor Vector Mode ED Motor Vector Mode	
	Contents	Scale	Contents	Scale
1	Output frequency	20000/Max.	Motor speed	20000/Max.
2	Frequency command (set frequency)	20000/Max.	Speed command (set speed)	20000/Max.
3	Output current	10000/100% ^{(*)3}	Output current	10000/100% ^{(*)3}
4	Output torque (torque current)	5000/100%	Output torque (torque current)	5000/100%
5	DC voltage	10/V ^{(*)1}	DC voltage	10/V ^{(*)1}
6	Output voltage	20/V ^{(*)2}	Output voltage	20/V ^{(*)2}
7	Motor speed	20000/Max.	Output frequency	10/Hz
8	Overload counter	10000/100%	Overload counter	10000/100%
9	Line speed	20000/Max.	Line speed	20000/Max.
10	Motor temperature	10/°C	Motor temperature	10/°C
11	Input terminal check 1	—	Input terminal check 1	—
12	Input terminal check 2	—	Input terminal check 2	—
13	Input terminal check 3	—	Input terminal check 3	—
14	Input terminal check 4	—	Input terminal check 4	—
15	Output terminal check 1	—	Output terminal check 1	—
16	Output terminal check 2	—	Output terminal check 2	—
17	Accumulation operation time	1/hr	Accumulation operation time	1/hr
18	Timer remaining time 1	1/hr	Timer remaining time 1	1/hr
19	Timer remaining time 2	1/hr	Timer remaining time 2	1/hr
20	Inverter uint version	—	Inverter uint version	—
21	PLC function version	—	PLC function version	—
22	Analog input voltage	100/V	Analog input voltage	100/V
23	Monitor for adjustment	—	Monitor for adjustment	—
24	Not used (Undecided)	—	Not used (Undecided)	—
25	Not used (Undecided)	—	Not used (Undecided)	—

*1: The scale is 5/V in 400V system.

*2: The scale is 10/V in 400V system.

*3: 100% of value is a value which multiplied inverter amperage rating (A) by the gain shown in the following page. Refer to the instructions manual of the main part of a VF66B inverter for inverter amperage rating.

Table 3.14 The Gain of Each Model

VF66B				VF66A			
Capacity	Gain	Capacity	Gain	Capacity	Gain	Capacity	Gain
2R222	10	2R244	100	2R222	10	2R244	100
3R722	10	3R744	100	3R722	10	3R744	100
5R522	10	5R544	10	5R522	10	5R544	10
7R522	10	7R544	10	7R522	10	7R544	10
1122	10	1144	10	1122	10	1144	10
1522	10	1544	10	1522	10	1544	10
2222	10	2244	10	2222	10	2244	10
3022	10	3044	10	3022	10	3044	10
3722	10	3744	10	3722	10	3744	10
4522	10	4544	10	4522	10	4544	10
5522	10	5544	10	5522	10	5544	10
7522	10	7544	10	—	—	—	—
9022	1	11044	10	—	—	—	—
15022	1	16044	10	—	—	—	—
18022	1	20044	1	—	—	—	—
—	1	25044	1	—	—	—	—
—	1	31544	1	—	—	—	—
—	1	40044	1	—	—	—	—
—	—	50044	1	—	—	—	—
—	—	60044	1	—	—	—	—
—	—	75044	1	—	—	—	—
—	—	10004	1	—	—	—	—

(6)Rewriting of setting data

As shown in the following table, the setting data of a VF66B inverter can be protected by rewriting protection setup. Rewriting protection is not set up in the initial state. Release of rewriting protection is checked before rewriting of setting data.

Tbale 3.15 Setup of inverter setting data rewriting protection

Console Display	Items	Item Selection	Default Data	Rewrites during Operation
b-00	Setting data rewrite protection	OFF (Inactive) ON (Activate protection)	OFF	×

Rewriting of setting data of a VF66B inverter is the following procedures.

- 1) Master station transmits the data write-in demand shown in figure 3.22 to OPCN66-Z, and directs rewrite of setting data, and the number of setting data, and the total byte size of the data to rewrite. Both of the setting data, 1st / 2nd setting block, can be rewrite. Since all data sizes are 1 word (2 bytes), the byte size of data serves as even number. In the case of odd number, a part for 1 byte of the last data is disregarded. 122 words data can be rewrite at the maximum at once.

At this time, byte size directions of 2nd word are set to 244 [bytes].

*** Ask separately about the setting data number of a VF66B inverter.**

- 2) OPCN66-Z replies the received data to a master station as it is as a data write-in response.
- 3) By data readout demand, as a master office transmits a processing result to OPCN66-Z, it transmits demand data. The demand data at this time becomes the same as 1).
- 4) As a data readout demand, OPCN66-Z gives a S/F (success or failure of processing) bit to 1st word, and replies monitor data(figure 3.23). 122 words setting data is transmitted at the maximum at once. When rewriting of setting data goes wrong, "FFFFh" is written in the part of the data.

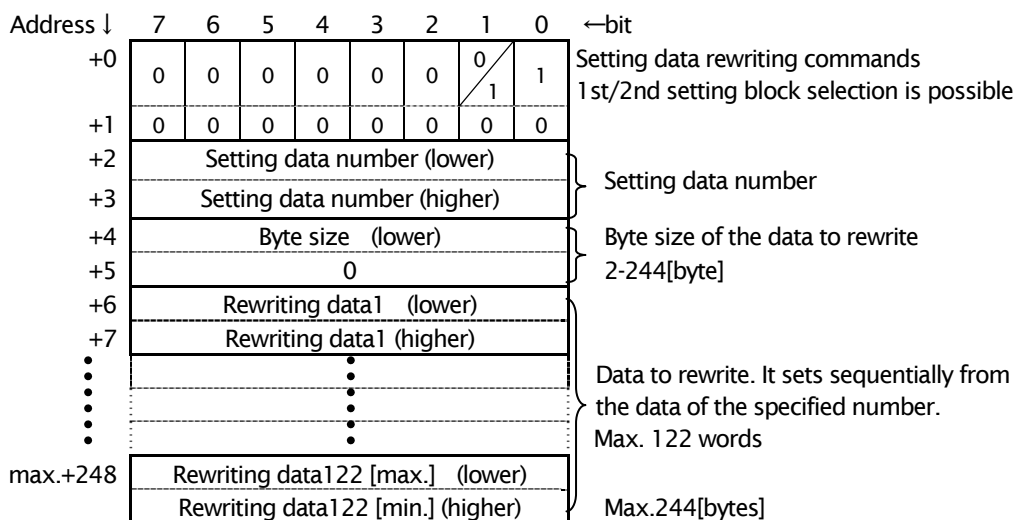

Figure 3.22 Data composition of the master station data write-in demand SDU (Setting data write-in command)

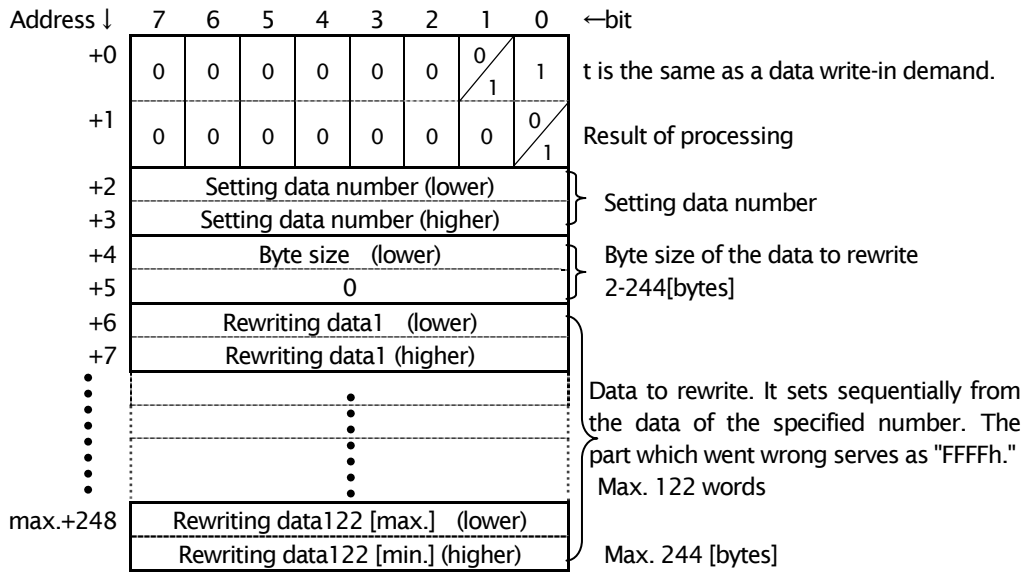

Figure 3.23 Data composition of the master station data readout check SDU (Setting data readout result)

3. 4 Function using simultaneous transmitting service

By simultaneous report service, the data equivalent to the output data of the input/output service stated to 3.2 (1) can be transmitted to all the VF66B inverters. In this case, please make the same as iodataM of the input/output demand SDU shown in Fig. 3.1 data composition of the simultaneous report demand SDU which a master office transmits. In addition, len of the simultaneous report demand SDU is applied to the length of effective data, and a setup of J-05 is disregarded.

3. 5 Function using reset service

By reset service, OPCN66-Z will be in the state before initial setting service reception, after replying a reset response.

TOYODENKI SEIZOK.K.

<http://www.toyodenki.co.jp/>

HAED OFFICE: No.1 Nurihiko Bldg. 9-2 Kyobashi 2-chome Chuo-ku,
Tokyo, Japan ZIP CODE 104-0031

TEL : +81-3-3535-0652~3

FAX : +81-3-3535-0660

OSAKA BRANCH : Higashi Hankyu Bldg. Kakuta-cho 1-1,
Kita-ku Osaka, Japan ZIP CODE 530-0017

TEL : +81-6-6313-1301

FAX : +81-6-6313-0165

NAGOYA BRANCH : Toyo Bldg. 14-16, Meieki 3-chome
Nakamura-ku Nagoya, Japan ZIP CODE 450-0002

TEL : +81-52-541-1141

FAX : +81-52-586-4457

Contents of this manual are subject to change without notice.

QG18745

2011-1 issued