

<u>OPCN66-Z Operation manual</u>	No.	QG 1 8 7 4 4
	Issued Department	Industrial Business Division Industrial System Works Industrial Development Department

Mark	Date	Records	Applied No.	Pages of Correction	Approved	Designed	Drawn
—		Issue	X	—			

--	--	--	--	--	--	--	--

Foreword

Thank you for choosing Toyo VF66B inverter product.

This instruction manual contains information regarding the OPCN66-Z Optional Circuit Board for the VF66B Inverter. For correct use, please carefully read this instruction manual prior to using the OPCN66-Z.

In order to accommodate the many special functions to a wide variety of applications in addition to the basic inverter functions, please thoroughly read the VF66B inverter manual as well as any other applicable specialized instruction manuals.

This instructions manual explains a setup of the function of OPCN66-Z, the wiring method, and a VF66B inverter. Refer to a "OPCN66-Z communications protocol description" for OPCN-1 communication function.

Please read before use

For safety

Before installing, operating, maintaining and inspecting OPCN66-Z option, please read this manual and all other appendices thoroughly in order to get familiarize with the feature of this option, safely information and correct handling. For safe operation, be sure to also thoroughly read the VF66B Inverter operating manual. In this instruction manual, the safety instructions are classified in to two levels: DANGER and CAUTION.



Indicates a hazardous situation which may result in death or serious injury if it is handled improperly.



Indicates a hazardous situation which may result in moderate or minor injury or only in property damage if it is handled improperly. However, such a situation may lead to serious consequences depending on circumstances.

CAUTION [Installation]

- Do not use optional circuit board if you discover damage or deformation during unpacking.
Doing so may cause optional circuit board failure or malfunction.
- Do not place any flammable materials near the optional circuit board.
Doing so may cause a fire.
- Do not allow the optional circuit board to drop, fall over or sustain severe impacts.
Doing so may cause optional circuit board failure or damage.
- Do not install or operate the optional circuit board if it is damaged or has any of its parts missing.
Doing so may lead to personal injury.

DANGER [Wiring]

- Before wiring, make sure the power is OFF.
Failure to do so may cause an electric shock or fire.
- Wait more than 10 minutes after turning the power OFF before opening the unit case lid.
Failure to do so may cause an electric shock or fire.
- Make sure that the unit is correctly earthed.
Failure to do so may cause an electric shock or fire.
- Wiring must be done by skilled technicians.
Failure to do so may cause an electric shock or fire.
- Wire the unit after it is installed.
Failure to do so may cause an electric shock or fire.

CAUTION [Wiring]

- Make sure that communication cables and connectors are properly installed and locked in place.
Failure to do so may cause optional circuit board failure or malfunction.

DANGER [Operation]

- Turn the power ON after fitting the inverter front cover.
Do not remove the cover while the power is ON.
Doing so may cause an electric shock.
- Do not operate any switch with wet hands.
Doing so may cause an electric shock.
- Do not touch the inverter terminals while the power is ON, even if the inverter is in the idle state.
Doing so may cause an electric shock.
- If the alarm is reset while the operation signal kept input, the inverter will suddenly restart. Reset the alarm after making sure that the operation signal is OFF.
Failure to do so may lead to personal injury.
- The inverter can be set to operate in a wide range of speed. Operate the inverter after sufficiently checking the allowable range of the motor and equipment.
Failure to do so may cause personal injury, equipment failure or damage.

CAUTION [Operation]

- The inverter radiating fin and the radiating resistance are hot. Do not touch them.
Failure to follow this warning may cause burns.

DANGER [Maintenance, inspection and parts replacement]

- Always turn the power OFF before inspecting the inverter.
Failure to do so may cause an electric shock, personal injury or fire.
- Unauthorized persons shall not perform maintenance, inspection or parts replacement.
Use insulated tools for maintenance and inspection.
Failure to do so may cause electric shock or personal injury.

DANGER [Other]

- Never modify the unit.
Doing so may cause electric shock or personal injury.

CAUTION [General precautions]

Some illustrations given in this manual show the inverter from which the covers or safety shields have been removed to illustrate the details. Before operating the inverter, reinstall the covers and shields to their original positions and the inverter according to this manual.
These safety precautions and specifications stated in this manual are subject to change without notice.

Table of contents

Please read before use	3
For safety	3
Chapter 1 Functional outline	6
Chapter 2 Basic Specification	7
2. 1 Multifunction Input/ Output Terminal Specification	7
2. 2 Analog Input/ Output Terminal Specification	8
2. 3 P G Input/Output Terminal Specification	8
2. 4 OPCN-1 Communication Terminal Specifications	8
2. 5 OPCN-1 Communication Specifications	9
2. 6 Other	10
Chapter 3 Description of Substrate	11
3. 1 Name of Each Part	11
3. 2 OPCN66-Z switches	12
3. 2 Installation of OPCN66-Z	13
3. 4 L E D Operation	15
Chapter 4 Multifunction Input/ Output Specification	16
4. 1 Multifunction Input	16
4. 2 Multifunction Output	18
Chapter 5 Analog Input/Output Function	20
5. 1 Analog Input (2)	20
5. 2 Analog Input (2) Input Gain and Offset Adjustment	21
5. 3 Analog Input (2) Usage Instructions	23
5. 4 Analog output (2)	27
5. 5 Analog output (2) gain offset adjustment	28
Chapter 6 P G input/output function	30
6. 1 P G input signal	30
6. 2 P G Output signal	32
Chapter 7 OPCN-1 Communication Function	33
7. 1 Connection method of a communication cable	33
7. 2 Setup of OPCN-1 communication function	34

Chapter 1 Functional outline

OPCN66-Z is used equipping the connector of the PC board (VFC66-Z) in a VF66B inverter. The function of OPCN66-Z is equipped with an analog input/output function, multifunctional input/output function, and PG input/output function other than the communication function of an OPCN-1 slave station.

OPCN-1 is the standard specification of FA network of the device level which Japan Electrical Manufacturers' Association (JEMA) enacted, and it realizes the data communication network corresponding to a multi vendor.

By OPCN-1 communication function of OPCN66-Z, operation instructions, speed instructions, torque instructions, etc. are inputted into a VF66B inverter, or a monitor can do the operational status and the protection state of an inverter, current, voltage, etc. Moreover, the setting data of an inverter read-out/rewrites and read-out of trace back data, read-out of a protection history, and read-out of monitor data can be performed. Refer to a "OPCN66-Z communications protocol description" for OPCN-1 communication function. Moreover, it can be used as an input/output signal of the built-in PLC function of VF66B inverter. Refer to the description of VF66 PCTool for a built-in PLC function.

In order to reduce an environmental impact, OPCN66-Z is designed so that the content of a lead, mercury, cadmium, hexavalent chrome, PBB, and PBDE may be based on the RoHS instructions which EU defined.

CAUTION [Safety precautions]

Carefully read the instruction manual before use, and use the inverter correctly.

Our inverter and optional circuit board are not designed or manufactured for the purpose of use in life-support machines or systems.

If you intend to use the product stated in this document for special purposes, such as passenger cars, medical devices, aerospace devices, nuclear energy controls and submarine relaying machines or systems, consult our sales department.

This product is manufactured under strict quality control. However, if it is used in critical equipment in which inverter and optional circuit board failure may result in death or serious damage, provide safeguard to avoid serious accidents.

If you wish to use this inverter with loads other than three-phase AC traction, please contact us.

To use this product, electrical work is necessary. The electrical work must be done by qualified expert.

Chapter 2 Basic Specification

2. 1 Multifunction Input/ Output Terminal Specification

Multifunction Input/Output Terminal

Terminal No.	Use	Description
PS (2 Terminal)	+12V power terminal	Output +12V of DC voltage
G (2 Terminal)	GND terminal	Never connect GND terminal to the earth. Never touch nor connect PS terminal and G terminal.
MI6	Multifunction Input terminal (6)	(Maximum input voltage DC24V/Maximum input current 3mA) By input the signal in multifunction input terminal, the same operation can be done as that of console. [In the initial condition, the VF66B inverter setting parameter for the C area are set to: • For Multifunction input terminal (6), Preset speed selection 1 • For Multifunction input terminal (7), Preset speed selection 2 • For Multifunction input terminal (8), Preset speed selection 3 • For Multifunction input terminal (9), Accel./decel time selection 1 • For Multifunction input terminal (10), Accel./decal.time selection 2 • For Multifunction input terminal (11), Speed Up Command ※See each detailed mode instruction manuals for details of multifunction input terminals.
MI7	Multifunction Input terminal (7)	
MI8	Multifunction Input terminal (8)	
MI9	Multifunction Input Terminal (9)	
MI10	Multifunction Input Terminal (10)	
MI11	Multifunction Input Terminal (11)	
P	External Power Supply Connecting Terminal	
COM	Common Potential Connection Terminal	Never connect COM terminal to the earth.
MO3	Multifunction output terminal (3)	(Max. voltage DC24V/Max. Output Current 20mA) Multifunction output terminal outputs the signal depends on the situation of performance. [In the initial condition, the followings are set by VF66 Inverter Setting Parameter : H area. • For Multifunction output terminal (3), no use. • Multifunction output terminal (4), Torque detected. ※Refer to the instructions manual (each detailed mode) of VF66B inverter for the details of a multifunctional input terminal.
MO4	Multifunction output terminal (4)	

Multifunction Input Source Mode/Sink Mode Configuration Jumper Connector

Connector	Use	Description
CN-SO	Source Mode	• Setting Source Mode/Sink Mode is conducted by replacement of Jumper socket CN-SI, CN-SO. • In replacement of Jumper Socket, please cut off the power supply. [In the initial condition, the source mode is set.] • In case of source mode, the switch etc. is connected between Multifunction Input terminal (6) - (11) and PS Terminal, and turn on/off. • In case of sink mode, the switch etc. is connected between Multifunction Input terminal (6) - (11) and G Terminal, and turn on/off. For the detail information, please see the Chapter 4.
CN-SI	Sink Mode	

2. 2 Analog Input/ Output Terminal Specification

Analog Input/output function

OPCN66-Z Terminal TB1	Terminal No.	Use	Description
	AIN2	Analog Input Analog Input (2) Terminal	<ul style="list-style-type: none"> Type of input can be selected from 0~±10V, 0~10V, 4~20mA by the swift of SW1 and alternation of inverter setting parameter. (Please refer to Chapter 5 for the change of the input range.) Input resistance is 150kΩ in input analog voltage. Input resistance is 250Ω in input analog current. [0 to 10V is set in the initial condition.] ※See each detailed mode instruction manual of VF66B inverter for details of Analog Input Terminal (2).
	AOT2	Analog Output Analog Output (2) Terminal	<ul style="list-style-type: none"> By changing the VF66B inverter configuration parameters, the output range of the Analog Output (2) Terminal can be set to either 0 to 10V or 0 to ±10V (max current 1mA). [In the initial configuration, the inverter output current is set at "5V/Inverter rated current"] ※See each detailed mode instruction manual of VF66B inverter for details of analog output terminal (2).
G2	GND Terminal	Never connect G2 terminal to the earth.	

2. 3 P G Input/Output Terminal Specification

PG input/output function

OPCN66-Z Terminal TB2	Terminal No.	Use	Description
	+12	+12V power terminal	Output +12V of DC voltage
	G (3 terminals)	GND terminal	Never connect GND terminal to the earth.
	A	PG input terminal	Input A, B, U/Z, V, and W signal (complementary output) of 12 V power PG respectively.
	B		
	U/Z		
	V		
	W		
PG-OUT	PG output terminal	Outputs a divided waveform of the PG A-signal.	

2. 4 OPCN-1 Communication Terminal Specifications

OPCN-1 Communication

OPCN66-Z Terminal TB1	Terminal No.	Use	Description
	A	OPCN-1 Communication Communication Signal Terminal	·OPCN-1 communication terminal
	B		·Signal polarity of RS-485 (ISO/IEC8482)
	SG (2 terminals)	Communication Earth Terminal	·RS-485(ISO/IEC8482)Signal line data earth terminal
FG	Protective Earth Terminal	·FG terminal is used when grounding all the station	

2. 5 OPCN-1 Communication Specifications

OPCN1 Communication

Item	Specification																
Communication protocol	In conformity to JIS B 3511 (JEM-F3008)																
Applicable class of OPCN-1	TYPE-S521																
Electrical characteristics of physical layer	In conformity to RS-485 · +5V which insulated the power supply from the printed circuit board for inverter control through the built-in DC/DC converter is supplied.																
Objective devices of communication	Devices having specification of master station of OPCN-1 in addition to our uGPCsx, uGPCH																
Type of connection	Bus type (Multi-drop system)																
Transmission speed and transmission distance	To be set by built-in console of VF66B Inverter unit 125kpbs - 1000m or less 250kpbs - 800m or less 500kpbs - 480m or less 1Mbps - 240m or less																
Transmission procedure	Half duplex transmission																
Synchronization system	Frame synchronization																
Modulation system	Base band system																
Encoding system	NRZI (Non Return to Zero Inverted)																
Connection, wiring system	Terminal block (5 poles), 2 wires or 3 wires type																
Connection cable	Twisted pair cable with shield (CO-SPEV-SB(A)2Px0.5 is recommendable)																
Number of connection station	1~31 stations as slave station against master station of 1 unit																
Setting of station number	Setting by built-in rotary switch of OPCN66-Z PCB																
Communication control system	Polling/selecting system																
Error check system	16 bits FCS (Frame check sequence) by a Cyclic Redundancy Check (CRC-CCITT)																
Network service	<table border="1"> <tr> <td>Initial setting service</td> <td>○</td> </tr> <tr> <td>Input/output service</td> <td>○</td> </tr> <tr> <td>Data readout service</td> <td>○</td> </tr> <tr> <td>Data writing service</td> <td>○</td> </tr> <tr> <td>Reset service</td> <td>○</td> </tr> <tr> <td>Simultaneous communication all together</td> <td>○</td> </tr> <tr> <td>Message reading service</td> <td>×</td> </tr> <tr> <td>Messgae writing service</td> <td>×</td> </tr> </table>	Initial setting service	○	Input/output service	○	Data readout service	○	Data writing service	○	Reset service	○	Simultaneous communication all together	○	Message reading service	×	Messgae writing service	×
Initial setting service	○																
Input/output service	○																
Data readout service	○																
Data writing service	○																
Reset service	○																
Simultaneous communication all together	○																
Message reading service	×																
Messgae writing service	×																

2. 6 Other

Other standard specifications apply to VF66B inverter correspondingly. For more details, please refer to the VF66B inverter manual.



DANGER [Wiring]

- Before wiring, make sure the power is OFF.
Failure to do so may cause an electric shock or a fire.
- Substitution of Jumper socket is performed after certainly turning off an inverter.
Failure to do so may cause an electric shock, personal injury, equipment failure or malfunction.



CAUTION [Wiring]

- G terminal, G terminal, and G2 terminal are not connected to a grounding by any means.
Doing so may cause equipment failure or damage.
- Never connect or allow contact between the PS and G terminals.
Doing so may cause equipment failure or damage.

Chapter 3 Description of Substrate

3. 1 Name of Each Part

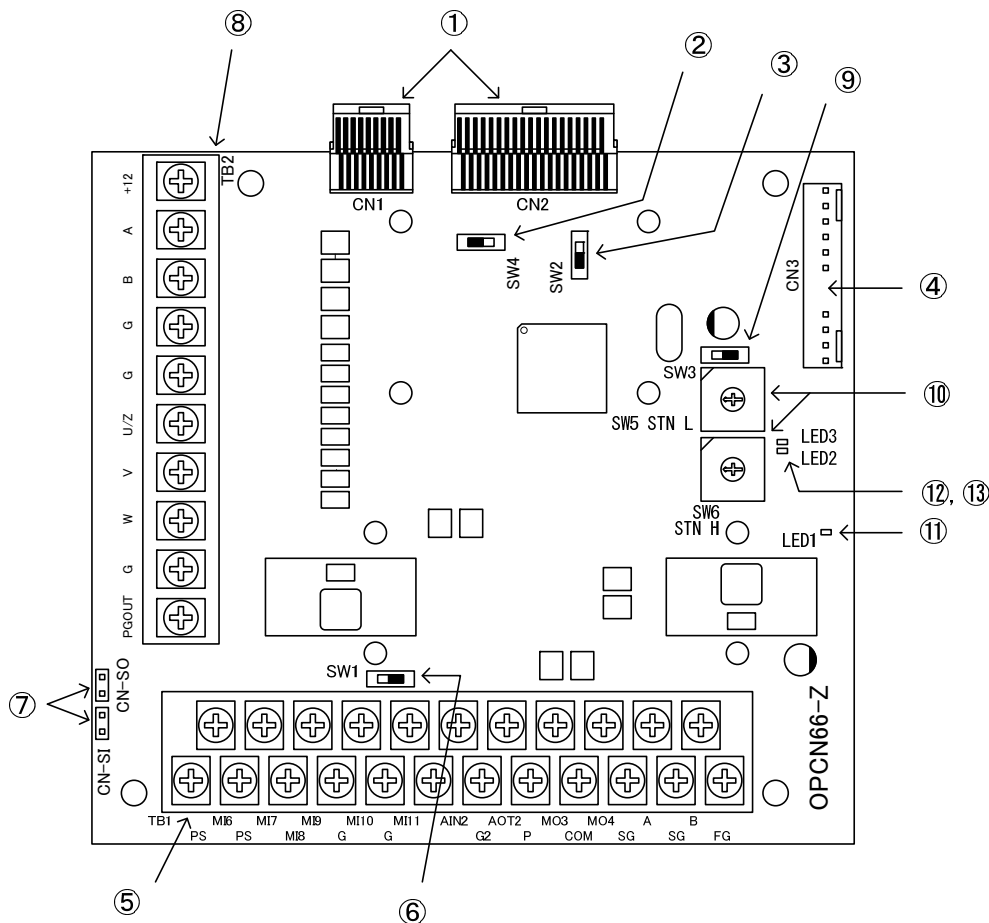

Figure3.1 OPCN66-Z substrate

- ① Connector to VFC66-Z (CN1,2)
- ② PG frequency dividing output switch (SW4)
- ③ PG signal ON/OFF switch (SW2)
- ④ Connector to external extension option "IOEXT66" (CN3)
- ⑤ Multi function input/output, Analog input/output terminal block (TB1)
- ⑥ Analog input(2) signal characteristic switching switch (SW1)
- ⑦ Multi function input signal characteristic switching jumper connector (CN-SI, CN-SO)
- ⑧ PG input/output terminal block (TB2)
- ⑨ OPCN-1 communication mode changeover switch (SW3)
- ⑩ OPCN-1 station number setting switch (SW5, SW6)
- ⑪ Power supply supply LED (LED1, PWR, green) of OPCN-1 communication
- ⑫ LED (LED2, ALRM, red) for abnormality displays of OPCN-1 communication
- ⑬ Display LED (LED3, COMN, yellow) of OPCN-1 communication of operation

As connector connecting to ④, please use housing :5051-12, terminal coated gold :2759G or 2759PBG produced by Molex. For connection to CN3 and usage of CN3 and so on, refer to the instruction manual about IOEXT66.

3. 2 OPCN66-Z switches

The switch on OPCN66-Z can be switched and various functions can be changed.

Each kind of function of switch on OPCN66-Z

Name of switch	Use	Description
SW1	Analog input(2) signal characteristic switching switch	Switch input signal characteristic of analog input (2) terminal. <ul style="list-style-type: none"> • 0-10V,0±10V input when the switch is OFF. • 4-20mA input when the switch is ON. [In the initial condition, the switch is set to OFF.] ※When you switch input range, please change the parameter of VF66B inverter. For more detail, please refer to chapter 5.
SW2	PG signal ON/OFF switch	Switch ON/OFF PG signal. <ul style="list-style-type: none"> • PG signal is no effect when the switch is OFF. • PG signal is available when the switch is ON. [In the initial condition, the switch is ON.]
SW3	OPCN-1 communication mode changeover switch	The communication mode of OPCN-1 is switched. <ul style="list-style-type: none"> • When a switch is OFF, it is in JIS B 3511 conformity communication mode. • When a switch is ON, it is in communication mode with the master station of the original communication specification of our company sold before this standard establishment. ※refer to a "OPCN66-Z communications protocol description" for details. [In the initial condition, the switch is OFF.]
SW4	PG frequency dividing output switch	Switch output of PG frequency dividing signal. <ul style="list-style-type: none"> • 1/4 frequency dividing signal is output when the switch is side of 3. • 1/2 frequency dividing signal is output when the switch is side of 1. [In the initial condition, the switch is set to position "3"]
SW5,SW6	OPCN-1 station number setting switch	Station number of OPCN-1 is set up. <ul style="list-style-type: none"> • Station number is set up by the hexadecimal number of double figures, is SW5 about a low rank digit, and sets up a higher rank digit by SW6. • Since OPCN66-Z is slave station, station number sets up 01H - 7FH.



DANGER [Switch]

- Change of a switch is performed by certainly turning off the inverter.
Failure to do so may cause an electric shock, personal injury, equipment failure or malfunction.

3. 2 Installation of OPCN66-Z

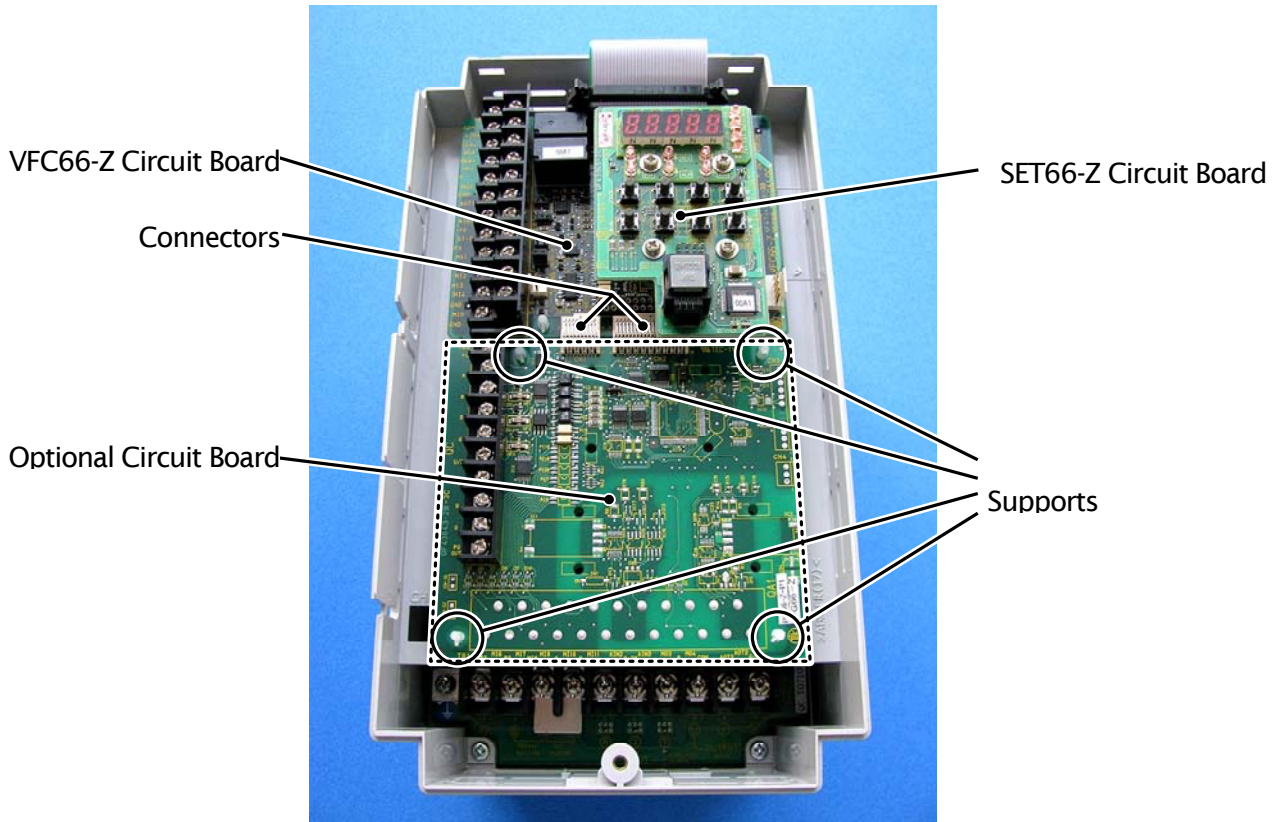

Figure 3.2 Optional Circuit Board Installation Position (VF66B-2R222)

*For information about opening and closing the inverter unit cover lid, please refer to the VF66B inverter manual.

- (1) Confirm that the power is off before performing any work.
- (2) Install the OPCN66-Z board in the location designated by the dotted lines shown in Figure 3.2. (The figure shows the VF66B-2R222 model, however, the installation location is the same for other models.) If another optional circuit board is already installed, remove it by following the procedure described below. If another optional circuit board is not already installed, skip to (6).
- (3) In order to safely remove the optional circuit board, first remove the SET66-Z board. Remove the 4 screws indicated by the circles in the figure on the right. Pull the SET66-Z board away from the VFC66-Z board in order to detach it.
- (4) Next, release the two connectors between the VFC66-Z board and the optional circuit board. Figure 3.4 (a) shows the connector in its engaged position. Pull up the tab to release the connector as shown in Figure 3.4 (b).
- (5) 4 board supports are included to mount the optional circuit board to the inverter housing, as indicated by the circles in Figure 3.2. Press down on the board support locking hooks as shown in Figure 3.5 to remove the optional circuit board.

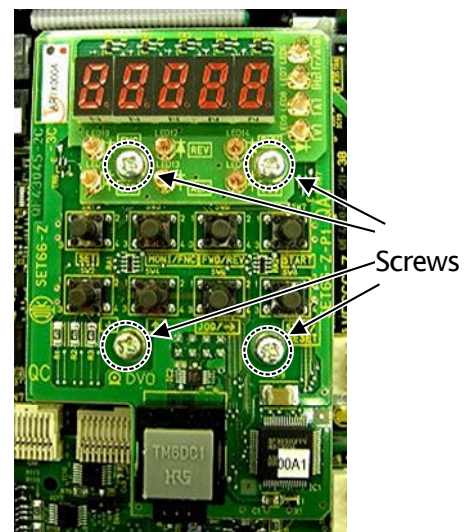

Figure 3.3 SET66-Z Circuit Board

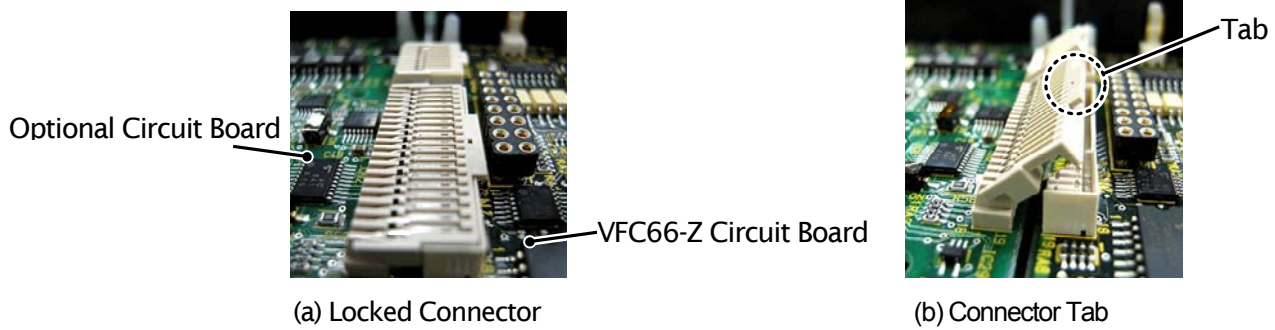

Figure 3.4 Connector

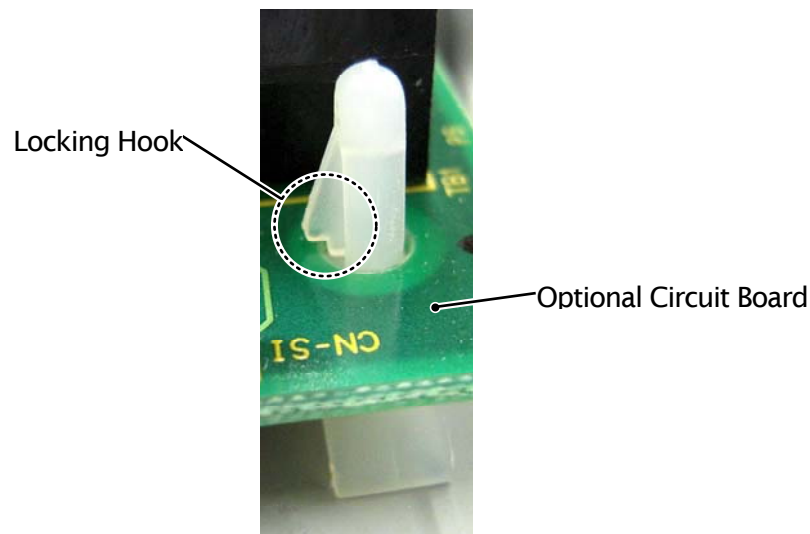

Figure 3.5 Support Locking Hook

- (6) Align the four holes of the OPCN66-Z board with the 4 board supports indicated by the circles in Figure 3.2. Push down on the board until the support locking hooks snap into place as shown in Figure 3.5.
- (7) Align the tabs (shown in Figure 3.4 (b)) of the OPCN66-Z board connectors CN1 and CN2 with the VFC66-Z board connectors CN7 and CN4. Press down on the tabs to engage with the connectors. Once the connectors are correctly joined, it will look like Figure 3.4 (a). The movable part of the connector has some elasticity and if the joint is weak, it may become disconnected. Ensure that it is properly locked in place.
- (8) Install the SET66-Z board to its original position.
- (9) Return the inverter unit cover lid to its original position.



DANGER [Installation/Removal]

- Always confirm that the power is off before installing/removing any circuit boards. Failure to do so may cause an electric shock, personal injury, equipment failure or malfunction.



CAUTION [Installation/Removal]

- Avoid excess connection and disconnection of the connectors. The connector mounting area may become loose, leading to problems such as poor connections.
- Do not attempt to insert any object other than a compatible connector. The connector mounting area may deform, leading to problems such as poor connections.

3. 4 LED Operation

- **LED1 Operation**

LED1 illuminates in a cycle of about 2 seconds when OPCN66-Z is operating normally. If LED1 is not illuminated properly when power is on, the following situations may be the cause:

- The connection between VFC66-Z and OPCN66-Z may be faulty.
- VFC66-Z or OPCN66-Z may be malfunctioning.



CAUTION [Safety Precautions]

- If LED1 is not operating normally, the OPCN66-Z or VFC66-Z board may be malfunctioning. If this is the case, please contact us immediately.

Chapter 4 Multifunction Input/ Output Specification

4. 1 Multifunction Input

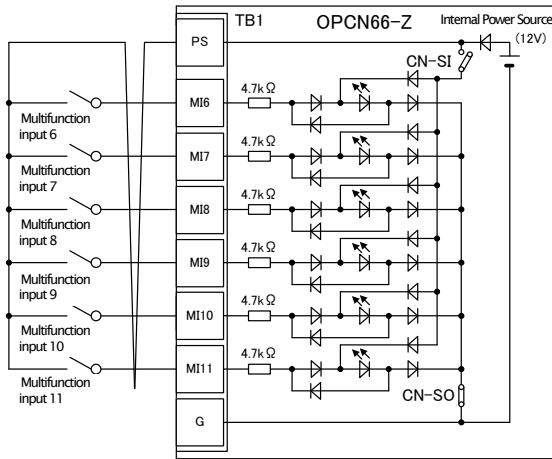

1. Source Mode (with internal power source)

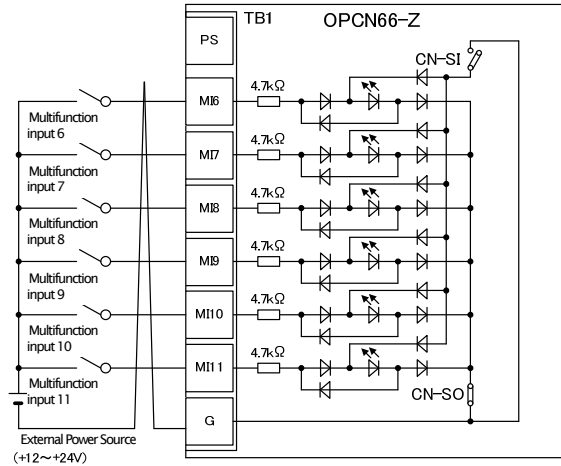

2. Source Mode (with external power source)

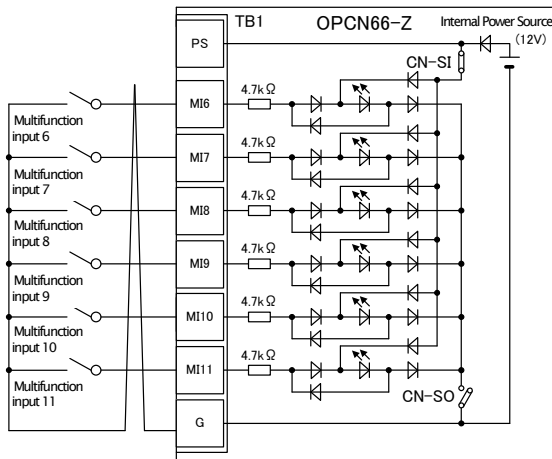

3. Sink Mode (with internal power source)

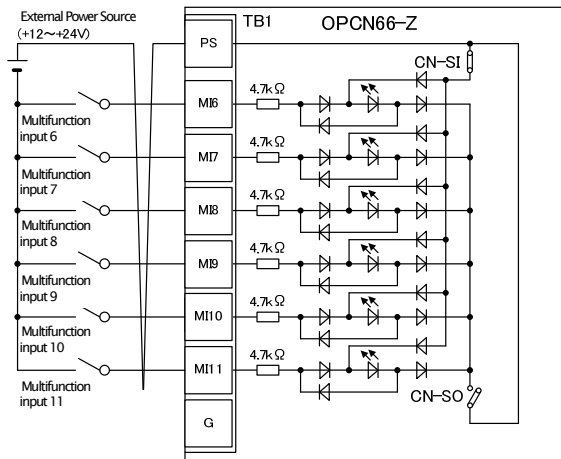

4. Sink Mode (with external power source)

Figure 4.1 Multifunction Input Connections

The OPCN66-Z can use the VF66B inverter multifunction input. The above figures show typical multifunction input signal connection methods. The **maximum allowable voltage is 24V** and the **maximum allowable current for any one terminal is 3mA**. For more information about the functions of the individual multifunction input terminals, please refer to the VF66B inverter manual.

The multifunction input signal can be set to either source mode or sink mode and an internal power source or external power source can be chosen for the inverter. In the initial configuration, it is set to source mode. To switch between source mode and sink mode, place a jumper shunt on either the IO66-Z jumper connector CN-SO (source mode) or CN-SI (sink mode).

Multifunction Input Related Inverter Parameters

Console Display	Items	Item Selection	Default Setting Data	Unit
c-00	Multifunction input place selection	0: Terminal block 1: Digital communication option	0: Terminal block	—
c-06	Multifunction input terminal (6) function selection	0: Preset frequency selection 1 (V/f mode) Preset rotation speed selection 1 (induction motor/ED motor vector mode)	0:Preset frequency selection 1	—
c-07	Multifunction input terminal (7) function selection	1: Preset frequency selection 2 (V/f mode) Preset rotation speed selection 2 (induction motor/ED motor vector mode)	1:Preset frequency selection 2	
c-08	Multifunction input terminal (8) function selection	2: Preset frequency selection 3 (V/f mode) Preset rotation speed selection 3 (induction motor/ED motor vector mode)	2:Preset frequency selection 3	
c-09	Multifunction input terminal (9) function selection	3: Acceleration/deceleration time selection 1 4: Acceleration/deceleration time selection 2 5: Frequency UP command (MRH mode) (V/f mode) Rotation speed UP command (MRH mode) (induction motor/ED motor vector mode)	3:Acceleration/ deceleration time selection 1	
c-10	Multifunction input terminal (10) function selection	6: Frequency DOWN command (MRH mode) (V/f mode) Rotation speed DOWN command (MRH mode) (induction motor/ED motor vector mode)	4:Acceleration/ deceleration time selection 2	
c-11	Multifunction input terminal (11) function selection	7: Frequency hold (V/f mode) Rotation speed hold (induction motor/ED motor vector mode)	5:Frequency UP command	
		8: S-pattern acceleration/deceleration prohibition 9: Max. frequency reduction (V/f mode) Max. rotation speed reduction (induction motor/ED motor vector mode) 10: Droop control disabled 11: No function (V/f mode) Speed/torque control selection (induction motor/ED motor vector mode) 12: Forward/reverse operation command selection 13: DC brake command 14: No function (V/f mode) Initial excitation command (induction motor/ED motor vector mode) 15: External failure signal 1 (protection relay 86A enable) 16: External failure signal 2 (protection relay 86A enable) 17: External failure signal 3 (protection relay 86A enable) 18: External failure signal 4 (protection relay 86A enable) 19: External failure signal 1 (protection relay 86A disabled) 20: External failure signal 2 (protection relay 86A disabled) 21: External failure signal 3 (protection relay 86A disabled) 22: External failure signal 4 (protection relay 86A disabled) 23: Trace back external trigger 24: Second set-up block selection 25: Emergency stop (B contact) 26: No function 27: Frequency commanding terminal block selection (V/f mode) Rotation speed commanding terminal block selection (induction motor/ED motor vector mode) 28: No function 29: Operation command [reverse] (STARTR) 30: Jog command [forward] (JOGF) 31: Jog command [reverse] (JOGR) 32: Emergency stop (A contact) 33: Protection reset (RESET) 34: External signal input 1 35: External signal input 2 36: External signal input 3 37: External signal input 4		

The multifunctional input of OPCN66-Z besides the input from a terminal block can be inputted from OPCN-1 communication. Either can be chosen with the inverter setting parameter c-00. Refer to a "OPCN66-Z communications protocol description" for the details of the multifunctional input by communication.

Moreover, the multifunctional input signal of OPCN66-Z can be used as an input relay of the built-in PLC function of VF66B inverter. For more information, refer to a "OPCN66-Z communications protocol description" and the instructions manual of the main part of VF66B inverter, and the description of VF66 PCTool.

⚠ DANGER [Wiring]

- Before wiring, make sure the power is OFF.
Failure to do so may cause an electric shock or a fire.
- Substitution of Jumper socket is performed after certainly turning off an inverter.
Failure to do so may cause an electric shock, personal injury, equipment failure or malfunction.

⚠ CAUTION [Wiring]

- G terminal and G2 terminal are not connected to a grounding by any means.
Doing so may cause equipment failure or damage.
- Never connect or allow contact between the PS and G terminals.
Doing so may cause equipment failure or damage.

4. 2 Multifunction Output

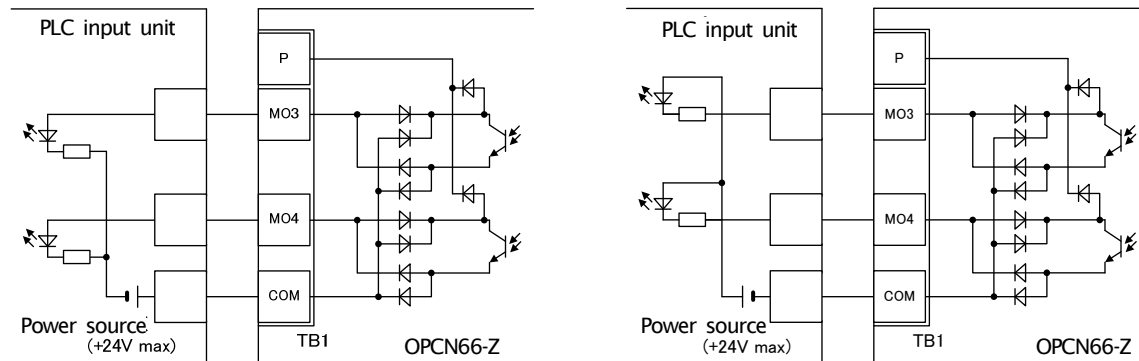

1. Connection with PLC (Source mode)

2. Connection with PLC (Sink mode)

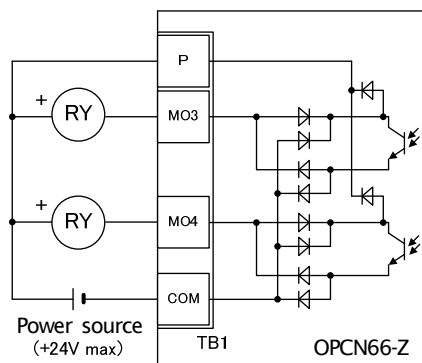

3. Connection with Relay

Figure 4.1 Multifunction Output Connections

The OPCN66-Z can use the VF66B inverter multifunction output. The above figures show typical multifunction output signal connection methods. Multifunction output is open collector output of transistor. In order to use it, DC power supply are required for the exterior. The **maximum allowable voltage is 24V** and the **maximum allowable current for any one terminal is 20mA**. For more information about the functions of the individual multifunction output terminals, please refer to the VF66B inverter manual.

Multifunction output Related Inverter Parameters

Console Display	Items	Item Selection	Default Setting Data	Unit
H-02	Multifunction output terminal (3) function selection	0: not used	0: not used	—
H-03	Multifunction output terminal (4) function selection	1: Frequency detection (1) (V/f mode) (Frequency = detection setting) Motor speed detection (1) (vector mode) (Motor speed = detection setting)	1: Torque detection	
		2: Frequency detection (1) (V/f mode) (Frequency \geq detection setting) Motor speed detection (1) (vector mode) (Motor speed \geq detection setting)		
		3: Frequency detection (1) (V/f mode) (Frequency \leq detection setting) Motor speed detection (1) (vector mode) (Motor speed \leq detection setting)		
		4: Frequency detection (2) (V/f mode) (Frequency = detection setting) Motor speed detection (2) (vector mode) (Motor speed = detection setting)		
		5: Frequency detection (2) (V/f mode) (Frequency \geq detection setting) Motor speed detection (2) (vector mode) (Motor speed \geq detection setting)		
		6: Frequency detection (2) (V/f mode) (Frequency \leq detection setting) Motor speed detection (2) (vector mode) (Motor speed \leq detection setting)		
		7: Reach setting		
		8: Torque detection		
		9: Torque detection (absolute value)		
		10: Power failure		
		11: Overload pre-alarm		
		12: Restart mode		
		13: In reverse operation		
		14: Protection operation code		
		15: not used		
		16: In operation		
		17: Extended schedule function (Usually, not set up)		
		18: Timer 1 setup time passes		
		19: Timer 2 setup time passes		
		20: 2nd set-up block selected		
		21: Fan motor failed		

When connecting a PLC input unit outside, OPCN66-Z can choose an connection in sink mode and source mode. Recommends using a twist line to a product line of PLC and OPCN66-Z. When connecting a relay externally, a coil uses a relay of a D.C. operation (for example, OMRON: G7L-2 A-T-DC 24V etc.). Since OPCN66-Z builds in the reflux diode which controls surge voltage, it certainly connects the + side terminal of external power source to P terminal of a terminal block in OPCN66-Z.

The OPCN66-Z multifunction output signal can also be used as the VF66B inverter built-in PLC function output relay. For more information, refer to a "OPCN66-Z communications protocol description" and the instructions manual of the main part of VF66B inverter, and the description of VF66 PCTool.



CAUTION [Wiring]

- Before wiring, make sure the power is OFF.
Failure to do so may cause an electric shock or a fire.
- COM terminal and G terminal in terminal block 1 are not connected to a grounding by any means.
Doing so may cause equipment failure or damage.

Chapter 5 Analog Input/Output Function

5. 1 Analog Input (2)

The Analog input (2) to the terminals on OPCN66-Z can be used as the input value to the rotation speed command value (or frequency command value), torque command value, and built-in PLC function by analog input (2) function.

For usage of Analog Input(2) function correctly, the correct VF66B Inverter parameter setting as mentioned below is required. Please refer the VF66B Inverter instruction manual together. Furthermore, for the built-in PLC function, please refer VF66 PC Tool manual.

Before usage of Analog Input(2), Please conduct the adjustment of gain as mentioned below.

Inverter setting parameter of analog input (2) input characteristics

Display	Item	Set-up range (Item selection)	Default Data	Unit
G-03	Analog input(2) characteristics selection	0:0 to $\pm 10V$ 1:0 to 10V 2:4 to 20mA	1	—

* If setting the torque command value as Analog Input (2), set this to "0". Only the 0 to $\pm 10V$ voltage input characteristic can be used.

The analog signal input into Analog Input (2) should be connected between the [AIN2] and [G2] terminals of the OPCN66-Z terminal block TB1, as shown in the following figures. The input analog signal characteristics can be chosen as either "voltage input 0 to $\pm 10V$ ", "voltage input 0 to 10V" or "current input 4 to 20mA", as shown in the above table. Choose an appropriate setting that matches the characteristics of the input signal. Also set the SW1 switch as shown in the following figures.

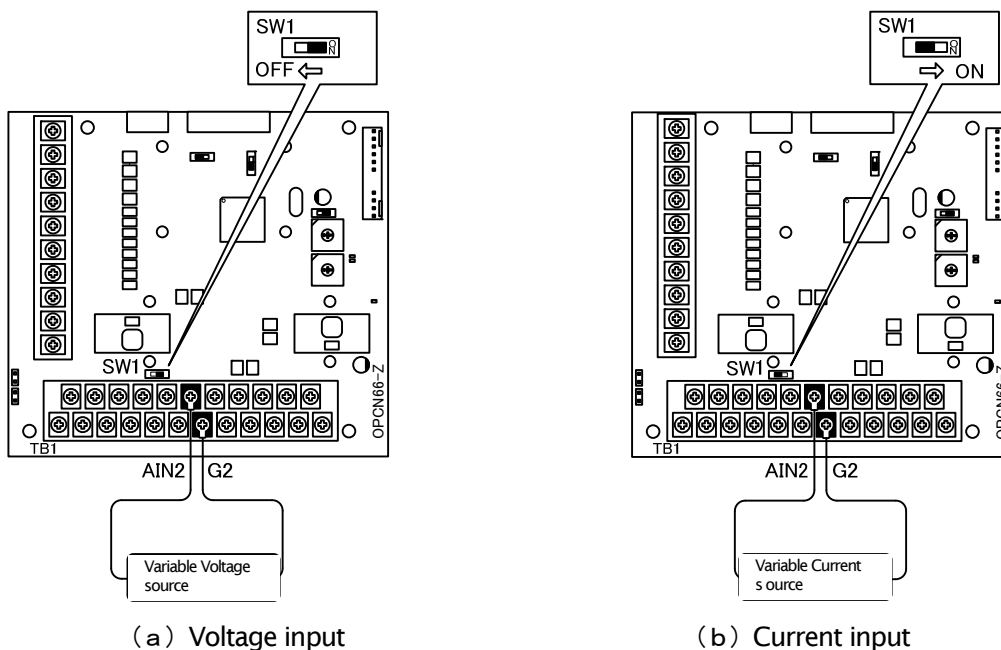

Figure 5.1 Connection of analog input (2)

5. 2 Analog Input (2) Input Gain and Offset Adjustment

Before usage of Analog Input (2), gain and offset adjustment are required. Adjustment is conducted under the temperature about 25°C.

Gain offset of an analog input (2) is adjusted after adjustment of gain offset of the analog input (1) of the main part of VF66 inverter. Please refer to the instructions manual of the main part of VF66B inverter for the adjustment method of gain offset of an analog input (1). Since it is adjusted at the time of factory shipments, it is not usually necessary to adjust gain offset of an analog input (1).

Inverter setting Parameter related to Analog Input(2) gain and offset adjustment

Display	Items	Set-up range (Item selection)	Default Data	Unit
L-05	Analog input(2) gain	50.00 to 150.00	100.00	%
L-06	Analog input(2) offset	-50.00 to 50.00	0.00	%
S-08	Analog input(2) adjust	1. Analog Input(2) Offset Adjustment Input the Analog(2) Voltage x 1000 Analog Input(2) Gain adjustment	-	-

(1) Input Characteristics “0 to ±10V” or “0 to 10V”



Press [MONI/FNC]key to turn on FNC (function selection) mode (LED-FNC will be lit).



Use [↑][↓]keys to select 「G-03」 and press [SET] key to confirm it.



Use [JOG/→]key to shift the digit to right, and [↑][↓]keys to input “0” and press [SET]keys to confirm it.

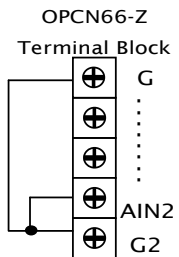

Turn Off the inverter, open the front cover, and short circuit between [AIN2] [G] [G2] terminal on the terminal block of optional PCB (OPCN66-Z).

⚠ CAUTION [Short-Circuit of terminals]

- Before short circuiting terminals, please be sure to turn OFF the inverter. There is a risk of electrical shock.

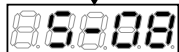

After power is ON, press [MONI/FNC]key to turn on FNC (function selection) mode. (LED-FNC will be lit). Use[JOG/→] [↑][↓]keys to select 「S-08」, and press [SET] key to confirm it.



Use [JOG/→] [↑][↓]keys to input 「1040」 and press[SET]key to confirm it.



「S-08」 will appear again, press[SET]key to confirm.



Use [JOG/→] and [↑][↓]keys to select “1” and press[SET]key to confirm it.

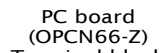
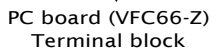

Turn OFF the inverter, open the front cover, and short circuit between [AIN2] on the terminal block TB1 of the OPCN66-Z PC board and [+10] on the terminal block TB1 of the VFC66-Z PC board. Remain short circuited terminals between [G] and [G2] of the PC board(OPCN66-Z)

⚠ CAUTION [Short-Circuit of terminals]

- Before short circuiting terminals, please be sure to turn OFF the inverter. There is a risk of electrical shock.

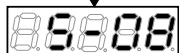

After power is ON, press[MONI/FNC]key to turn on FNC (function selection) mode. (LED-FNC will be lit) then, use [JOG/→] [↑][↓]keys to select 「S-08」 and press [SET]key to confirm.



Use [JOG/→] [↑][↓]keys to change numbers, Input 「1040」 and press [SET]key to confirm.



「S-08」 will appear again, press [SET]key to confirm.

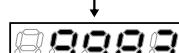

Measure the voltage between PC board (OPCN66-Z) terminals [AIN2] and [G] with a tester and enter the 1000times of the measured value. If measurement is not available, the value”9930” can be used. However accuracy is inferior

⚠ CAUTION [Voltage measurement]

When the voltage between the terminals is measured, please be sure not to touch wirings or terminals. There is a risk of electrical shock.

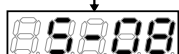

If 「S-08」 appears again, Analog input (2) gain (L-05) and Analog input (2) Offset (L-06) will be changed automatically. Press [MONI/FNC]Key to indicate monitor items.

When adjustment is done, turn OFF the inverter, open the front cover and remove the short circuit wirings installed between terminals, [AIN2]and [+10] of VFC66-Z PC board, as well as [G] and [G2] on the PC board (OPCN66-Z).

(2) Input Characteristics of “4~20mA”

※Conduct this after adjustment of aforementioned “(1) if the input characteristics is 0 to ±10V or 0 to 10V”

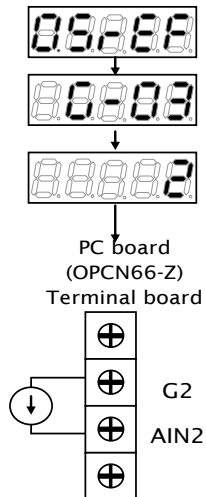

Press [MONI/FNC]key to turn on , FNC (function selection) mode. (LED-FNC will be lid)

Use [↑][↓]keys to select 「G-03」 ,press [SET]key to confirm.

Use [JOG/→][↑][↓]key to change the numbers and input 「2(4-20mA)」 and press[SET]key to confirm it.

Turn off the inverter, open the front cover and connect the current power between terminals [AIN2] And [G2] on the terminal block of PC board (OPCN66-Z)

Turn the SW1 ON (terminal block side) while the power of inverter is OFF.

⚠ CAUTION [Connection of current power]

- Before connecting current power, please be sure to turn OFF the inverter.
There is a risk of electrical shock
- Please be sure to turn OFF the inverter before switching a switch.
There is a risk of electrical shock.

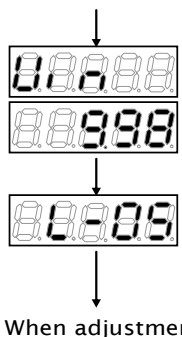

- After power is ON, select 「2」 in 「G-16」 and use monitor item[↑][↓]keys to select 「Vin」 input voltage of Analog input(2) appears in 「Vin」
- Turn the current power ON and input 20mA to [AIN2] terminal.
- A number will be displayed.
- Adjust the value 「L-05」 so that the value of monitor item 「Vin」 becomes 「10.00」 .

When adjustment is done, remove the current power.

5. 3 Analog Input (2) Usage Instructions

Before using the Analog Input (2) function, perform gain and offset adjustment as described in the preceding section.

Through the Analog Input (2), the input analog signal can be set to be the rotation speed command value (or frequency command value), torque command value or built-in PLC input value. The following explanation is for when it is set as the rotation speed command value or the torque command value. For instructions when using it as the input value to the built-in PLC, please refer to the VF66 PCTool manual.

(1) When using the input as a rotation speed command value

When using the analog input as a rotation speed command value, the inverter configuration parameters shown in the following table must be set.

Analog Input Rotation Speed Command Settings

Console Display	Items	Set-up Range (Item Selection)	Default Data	Unit
b-10	Rotation speed commanding input place selection	0: Coupled with b-09 1: Analog input (1) [VFC66-Z terminal block AIN1] 2: Console [SET66-Z] 3: Digital communication option 4: Analog Input (2) [Optional terminal block AIN2] 5: (For expansion option) 6: Analog Input (3) [Optional terminal block AIN3] 7: Built-in PLC function output	0	—
G-04	Analog Input (2) rotation speed upper limit	[Absolute value of Analog Input (2) rotation speed lower limit (G-05)] to [100.0] ^(*)	100.0	% ^(*)
G-05	Analog Input (2) rotation speed lower limit	-[Analog Input (2) rotation speed upper limit (G-04)] to [Analog Input (2) rotation speed upper limit (G-04)] ^(*)	0.0	% ^(*)

(*) This is set as a percentage with respect to the maximum rotation speed (configuration parameter A-00).

For more information about configuration parameter A-00, please refer to the VF66B inverter manual.

- Set b-10 to "4".
- Set G-03 (described in section 5.1) to a set value that matches the input signal characteristics.

• In the case of voltage input of 0 to ±10V

The rotational direction can be reversed by setting the command input voltage to a negative value. The rotation speed command value is set as the Analog Input (2) rotation speed upper limit (G-04) when the input is +10V. When the input is -10V, it is set as the negative value of the Analog Input (2) rotation speed upper limit (G-04). However, it is possible to set a lower limit by setting the Analog Input (2) rotation speed lower limit (G-05). (Figure 5.2, left) If the minimum rotation speed (A-01) is other than "0", the rotation speed command absolute value is controlled to prevent falling below the minimum speed. In this case, when the command input voltage is around the 0V range, its behavior shows hysteresis characteristics (It will run forward if started in the forward direction and will run in the minimum reverse speed if started in the reverse direction) as shown in the right side of Figure 5.2.

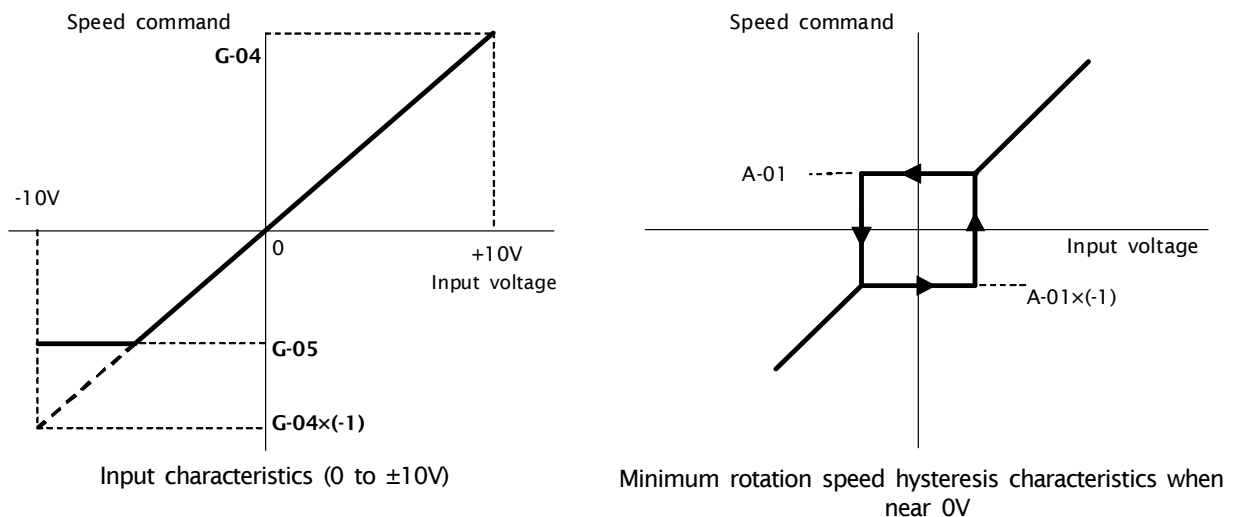

Figure 5.2 Speed command characteristics with voltage input of 0 to ±10V

• In the case of voltage input of 0 to 10V

The rotation speed command value is set as the Analog Input (2) rotation speed lower limit (G-05) when the input is 0V. When the input is 10V, it is set as the Analog Input (2) rotation speed upper limit (G-04). However, this will be set to “0” if the Analog Input (2) rotation speed lower limit (G-05) has a negative value. (Figure 5.3) If the minimum rotation speed (A-01) is other than “0”, the rotation speed command absolute value is controlled to prevent falling below the minimum speed. As a speed command, this only allows forward operation. For reverse operation, a reverse operation command should be used.

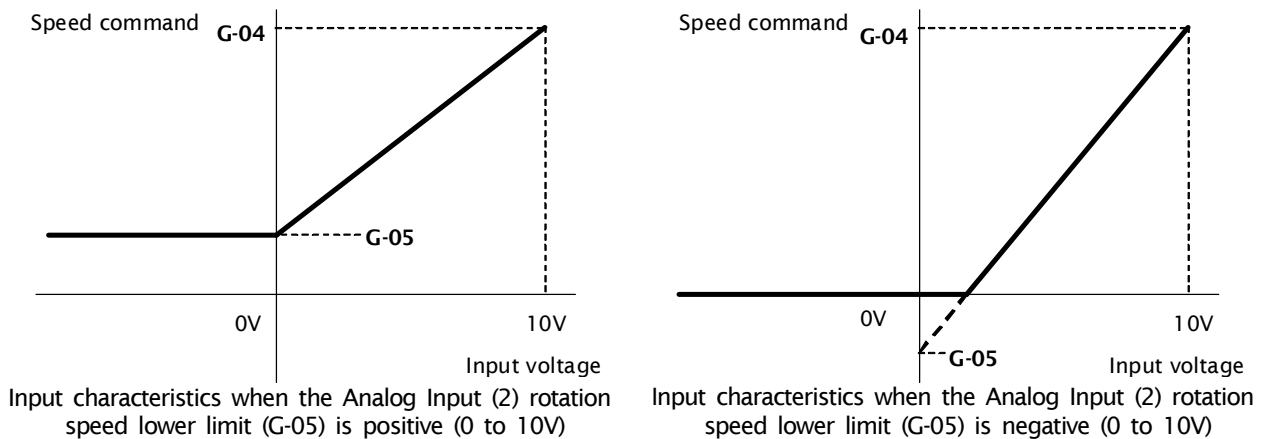

Figure 5.3 Speed command characteristics with voltage input of 0 to 10V

• In the case of current input of 4 to 20mA:

The rotation speed command value is set as the Analog Input (2) rotation speed lower limit (G-05) when the input is 4mA. When the input is 20mA, it is set as the Analog Input (2) rotation speed upper limit (G-04). However, this will be set to “0” if the Analog Input (2) rotation speed lower limit (G-05) has a negative value. (Figure 5.4) If the minimum rotation speed (A-01) is other than “0”, the rotation speed command absolute value is controlled to prevent falling below the minimum speed. As a speed command, this only allows forward operation. For reverse operation, a reverse operation command should be used.

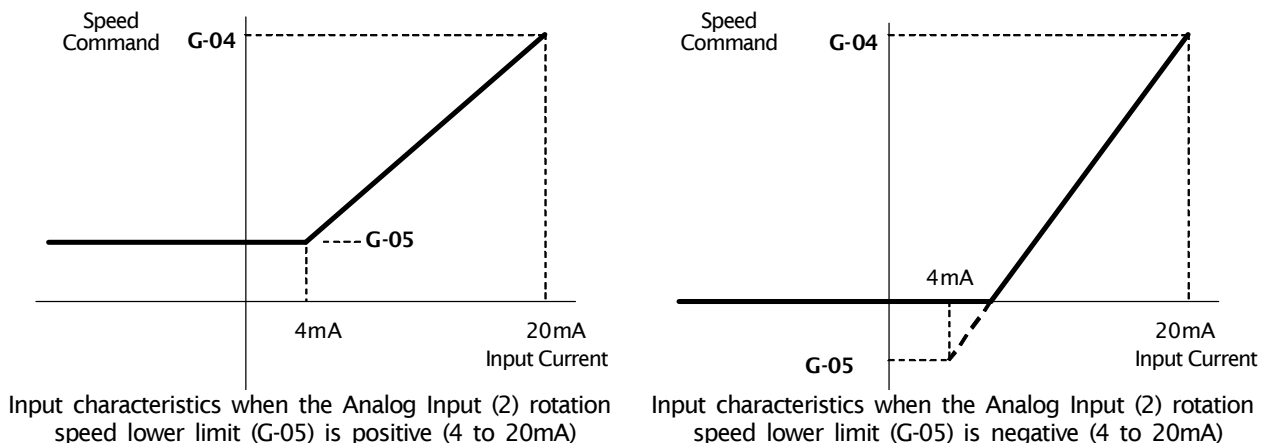

Figure 5.4 Speed command characteristics with current input of 4 to 20mA

(2) When using the input as a torque command value

When using the analog input as a torque command value, the inverter configuration parameters shown in the following table must be set.

* Torque command is disabled in V/f mode.

* The 4 to 20mA current input characteristic cannot be used for the torque command value. Only the 0 to ±10V voltage input characteristic can be used.

Inverter Configuration Parameters Related To Analog Input Torque Command

Console Display	Items	Set-up Range (Item Selection)	Default Data	Unit
i-08	Torque command input place selection	0: Analog Input (1) [VFC66-Z terminal block AIN1] 1: Analog Input (2) [Optional terminal block AIN2] 2: Digital communication option 3: Built-in PLC function output	1	—
i-09	Analog input torque command gain	50.0 to 200.0	150.0	%

- Set i-08 to “1”.
- Set G-03 (described in section 5.1) to “0”. Only the 0 to ±10V voltage input characteristic can be used.

The torque command value is set as the negative value of the analog input torque gain (i-09) when the input is +10V. When the input is -10V, it is set as the positive value of the analog input torque gain (i-09). (Figure 5.5)

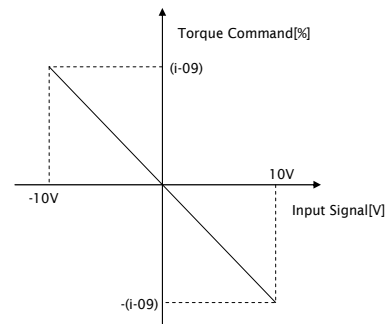

Figure 5.5 Analog Input Torque Command Characteristic

5. 4 Analog output (2)

By analog output (2) function, output voltage of inverter, rotation speed and internal variable of output of built in PLC function are output as analog signal. An analog signal is outputted between "AOT2" and "G2" of terminal block TB1. Analog output characteristic output by analog output (2) is "voltage output 0±10V". Please set the characteristic by setting parameter G-09. Please refer to operation manual about VF66B inverter with this manual. For built in PLC function, please refer to the operation manual about "VF66 PC Tool".

Please adjust analog gain and offset before using analog output (2) function.

Analog output setting

Console Display	Items	Set-up Range (Item Selection)	Default Data	Unit
G-09	Analog output(2) characteristic selection	0:Output voltage 1:Output current 2:Torque output (V/f mode) Torque command (vector mode) 3:Output frequency (V/f mode) Motor rotation speed (vector mode) 4:Output frequency command (V/f mode) Motor rotation speed command (vector mode) 5:Built in PLC output 6:Calibration 7:Internal monitor	1	—

Analog output selected by G-09

G-09	Selection items	Output voltage
0	Output voltage	7.5V/200V (200V class) 7.5V/400V (400V class)
1	Output current	5V/inverter rated current
2	Torque output (V/f mode) Torque command (vector mode)	5V/100%
3	Output frequency (V/f mode) Motor rotation speed (vector mode)	10V/maximum frequency (A-00) 10V/maximum rotation speed (A-00)
4	Frequency command (V/f mode) (*1) Motor rotation speed (vector mode) (*1)	10V/maximum frequency (A-00) 10V/maximum rotation speed (A-00)
5	Built in PLC output (*2)	5V/20000 (100%) (*2)
6	Calibration	5V
7	Internal monitor	—

(* 1) It is value after acceleration/deceleration control. For more information, please refer to the operation manual about VF66B inverter.

(* 2) When built in PLC output is selected, the value of output resistor "o00009" is output at the rate of 5V/20000. For more information, please refer to the operation manual about "VF66 PC Tool".

Analog output (2) is output between “AOT2” and “G2” on the terminal block TB1 of OPCN66-Z PCB.

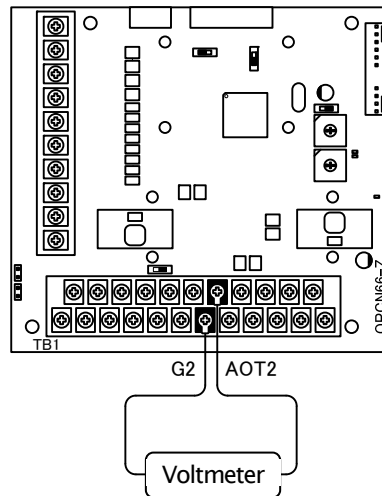

Figure 5.6 Connection of analog output (2)

5. 5 Analog output (2) gain offset adjustment

Before usage of Analog output (2), please adjust gain offset under the condition of 25[°C]
 Analog output (2) gain offset adjustment is conducted after the VF66B inverter analog input (1) gain offset adjustment. As to adjustment of analog input (1) gain offset, please refer the VF66B inverter instruction manual. Analog input (1) gain offset is adjusted when the inverter is shipped from our works, therefore analog input (1) gain offset is not necessary to adjust.

Inverter setting parameter related to Analog output gain offset adjustment

Console Display	Items	Set-up Range (Item Selection)	Default Data	Unit
L-09	Analog output(2) gain	50.0 to 150.0	100.0	%
L-10	Analog output(2) offset	-50.0 to 50.0	0.0	%
S-09	Analog output (2) adjust	1: Analog output (2) offset adjustment 2: Analog output (2) gain adjustment	-	-

(1) Adjustment of offset and gain of Analog output (2)

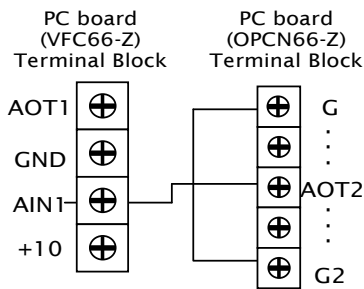

Turn OFF the inverter, open the front cover, and short circuit between terminals [AOT2] on the terminal block of the PCB(OPCN66-Z) and [AIN1] on the terminal block of PCB (VFC66-Z) and so as [G] and [G2] on terminal block of OPCN66-Z.



CAUTION [Short circuiting of terminals]

- Before short circuiting terminals, please be sure to turn OFF the inverter. There is a risk of electrical shock.

0.0000

After power is ON, press [MONI/FNC] key to turn on FNC (function selection) mode. (LED-FNC will be lit).

0.0000

After power is ON, press [MONI/FNC] key to turn on FNC (function selection) mode. (LED-FNC will be lit). Use [JOG/→] [↑][↓] keys to select "b-17" then press [SET] to confirm it.

0.0000

Use [JOG/→] [↑][↓] keys to input "0" and press [SET] key to confirm it.

0.0000

"b-17" appears again.

0.0000

Use [JOG/→] [↑][↓] keys to select "G-09" and press [SET] key to confirm it.

0.0000

Use [JOG/→] [↑][↓] keys to input "0" and press [SET] key to confirm it.

0.0000

"G-09" will appear again.

0.0000

Use [JOG/→] [↑][↓] keys to select "S-09" and press [SET] key to confirm it.

0.0000

Use [JOG/→] [↑][↓] keys to input "1040" and press [SET] key to confirm it.

0.0000

"S-09" will appear again, press [SET] key to confirm it.

0.0000

Use [JOG/→] [↑][↓] keys to input "1" and press [SET] key to confirm it.

0.0000

"S-09" will appear again.

0.0000

Use [JOG/→] [↑][↓] keys to select "G-09" and press [SET] key to confirm it.

0.0000

Use [JOG/→] [↑][↓] keys to input "6" and press [SET] key to confirm it.

0.0000

"G-09" will appear again.

0.0000

Use [JOG/→] [↑][↓] keys to select "S-09" and press [SET] key to confirm it.

0.0000

Use [JOG/→] [↑][↓] keys to input "1040" and press [SET] key to confirm it.

0.0000

"S-09" will appear again and press [SET] key to confirm it.

0.0000

Use [JOG/→] [↑][↓] keys to input "2" and press [SET] key to confirm it.

0.0000

If "S-09" appears again, Analog output (2) gain (L-09) and Analog output (2) offset (L-10) will be changed automatically.

Press [MONI/FNC] to indicate monitor items.

When adjustment is done, turn OFF the inverter, open the front cover, and remove the short circuit wirings installed between terminals [AOT2] on the OPCN66-Z PC board and [AIN1] on the VFC66-Z PC board, as well as [G] and [G2] on the OPCN66-Z PC board. Reset the setting of [G-09] and [b-17].

Chapter 6 PG input/output function

PG input/output functionality is used when driving a motor from the signal which detected the magnetic pole location and velocity of the rotor by the sensor (PG). PG is a correspondence only a complementary output with 12V power source. The operation manual of VF66B inverter (induction motor vector control mode or ED motor vector control mode) is referred to for a selection in PG mode, and an inverter mode change.

6. 1 PG input signal

In order to use PG input/output functionality, it is necessary to set correctly the inverter setups parameter shown in the following table according to the operation mode of an inverter, and PG specification to be used. Please also refer to the operation manual of VF66B inverter collectively.

※When switch SW2 on OPCN66-Z is ON, the input of PG signal is effective.

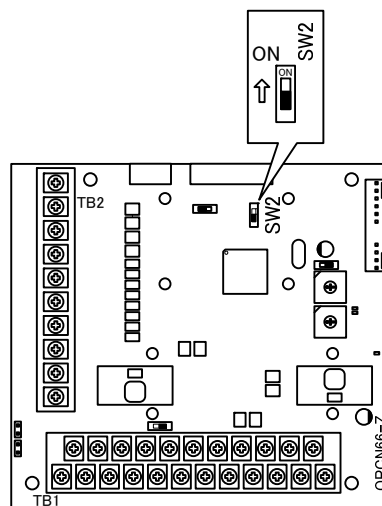

Figure 6.1 PG signal input switching

The inverter setups parameter of PG input signal setups

Console Display	Item	Set-up range (Item selection)	Set-up resolution	Default Data	Unit
A-10	PG Selection	V/f mode	(PG not used)	1	—
		Induction motor vector control mode	0: S-mode Sensor-less drive 1: V-mode with PG (AB phase input)	0	—
		ED motor vector control mode	0: S-mode Sensor-less drive 1: V-mode with PG (ABZ phase input) (*1) 2: P-mode with PG (ABUVW phase input) 3: RL-mode with resolver (resolution 10bit) (*2) 4: RH-mode with resolver (resolution 12bit) (*2)	0	—

(* 1) For special motors

(* 2) An option is required

(1) In the case of induction motor vector control mode

Please set 1 as the setups parameter A-10 shown in the upper table, and as shown in Fig. 6.2, connect PG wire to terminal block TB2 of OPCN66-Z. (Since it is not used, please do not connect U/Z, V, and W termination of TB2)

The recommendation cable of PG wire is CO-SPEV-SB(A)3P×0.5SQ (made by Hitachi Cable).

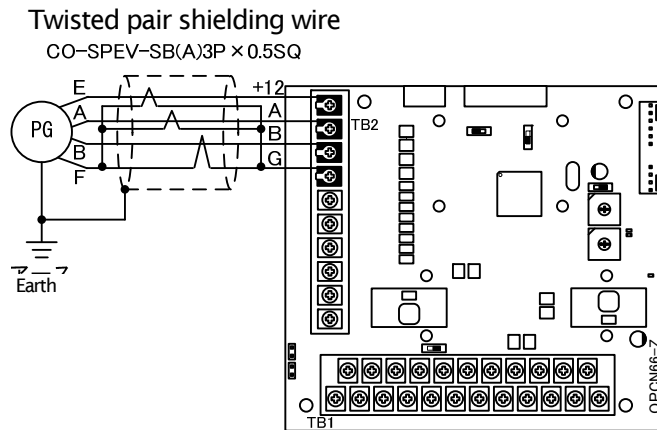

Figure 6.2 PG wire interconnection of an induction motor

(2) In the case of ED motor vector control mode

Please set 2 as the setups parameter A-10 shown in the upper table, and as shown in Fig. 6.3, connect PG wire to terminal block TB2 of OPCN66-Z. (As the setting value of "1" for A-10 is used for a special motor, it should not be selected for normal operation.)

The recommendation cable of PG wire is CO-SPEV-SB(A)7P×0.5SQ (made by Hitachi Cable). For ED motor PG connection, straight plugs (MS3106B-20-29S) and cable clamps (MS3057-12A) (Japan Aviation Electronics Industry, Ltd.) are required.

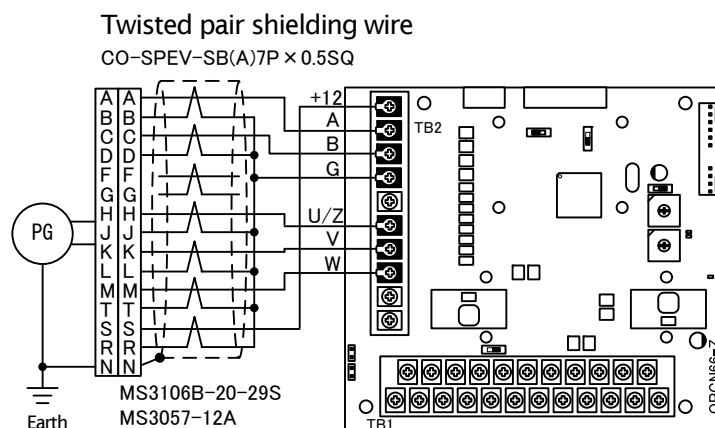

Figure 6.3 PG wire interconnection of an ED motor

⚠ DANGER [Wiring]

- When wiring PG, an inverter power source is certainly turned off. Failure to do so may cause an electric shock, personal injury, equipment failure or malfunction.
- Never connect the G terminal to earth. Doing so may cause equipment failure or damage.

DANGER [Switch]

- Change of a switch is performed by certainly turning off an inverter.
Failure to do so may cause an electric shock, personal injury, equipment failure or malfunction.

6. 2 PG Output signal

PG frequency dividing signal is outputted from A signal of PG input. Peak value is about 10v and duty 1:1. If SW4 of OPCN66-Z is switched to side of 3, 1 / 4PG frequency divided signal is outputted, and if SW4 is switched to side of 1, 1 / 2PG frequency divided signal is outputted. Please switch according to a destination.

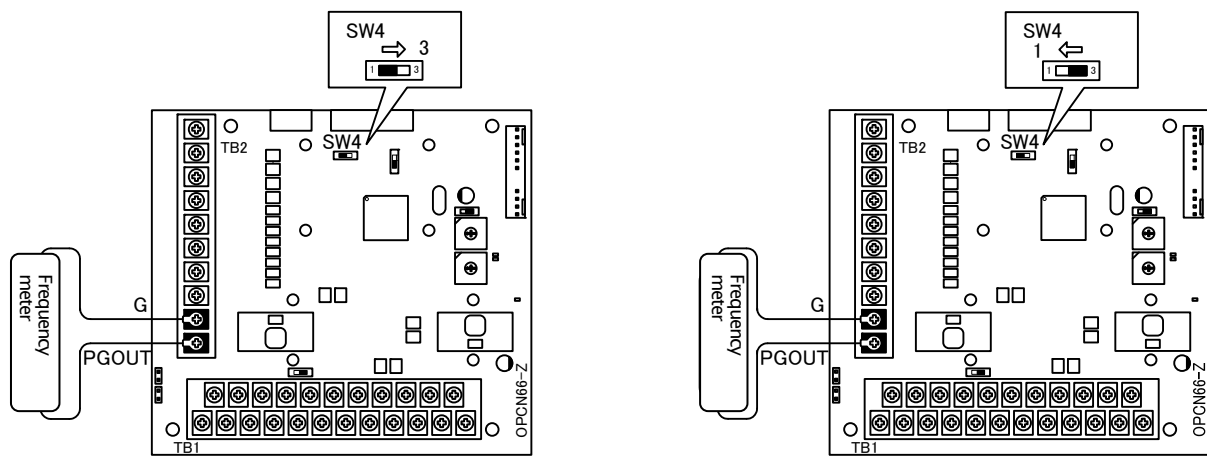

(a) 1 / 4PG frequency divided output

(b) 1 / 2PG frequency divided output

Figure 6.4 PG signal output

DANGER [wiring]

- Before connecting anything to the terminals, please be sure to turn off the inverter.
Failure to do so may cause an electric shock, personal injury, equipment failure or malfunction.
- Never connect the G terminal to earth.
Doing so may cause equipment failure or damage.

Chapter 7 OPCN-1 Communication Function

7. 1 Connection method of a communication cable

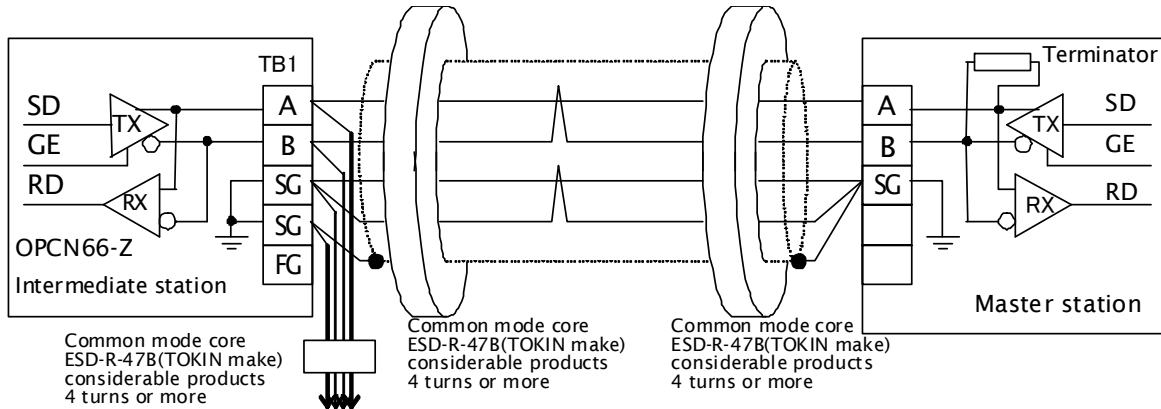

Figure 7.1 Connection with a master station

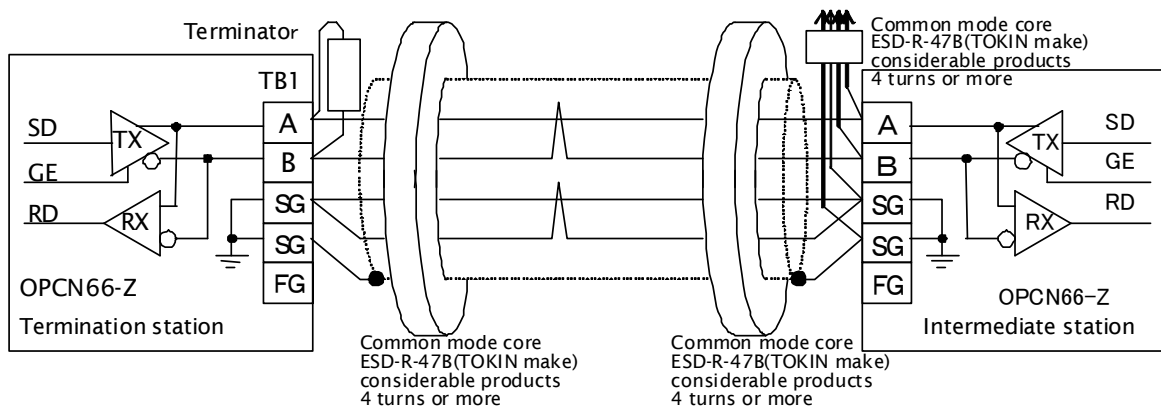

Figure 7.2 Connection with a termination station

The above figure shows the connection method with other offices. The example which uses the transmission cable of the twisted pair shield of 2P by a diagram is expressed (a transmission cable recommends CO-SPEV-SB(A)2Px0.5 of Hitachi Cable).

Please connect a terminator to an termination station.

When the terminator is not connected to the master station, please connect a terminator like an termination station.

※A shield line is connected to 0V (SG) terminal of the signal wire of a master station.

※When OPCN66-Z is an end office, a 100 ohms (more than 1W) terminator is connected among

Terminals A and B. Please cover the lead of a terminator by a clothing tube and the end of a lead should attach a pressure terminal (please solder a pressure terminal and a lead for the prevention from disconnection).

7. 2 Setup of OPCN-1 communication function

Through OPCN-1 communication, the OPCN66-Z can input operation and speed commands, torque commands and multifunction input to the VF66B Inverter as well as monitor factors such as operating conditions, protection conditions, current and voltage. It can also read and alter the inverter configuration data as well as read the trace-back data, protection history and monitor data.

For information about OPCN-1 communication, please refer to the "OPCN66-Z Communication Protocol Manual". Furthermore, it can be used as the input/output signal of the VF66B Inverter built-in PLC function. For information about the built-in PLC function, please refer to the VF66 PCTool manual.

TOYODENKI SEIZOK.K.

<http://www.toyodenki.co.jp/>

HAED OFFICE: No.1 Nurihiko Bldg. 9-2 Kyobashi 2-chome Chuo-ku,
Tokyo, Japan ZIP CODE 104-0031

TEL : +81-3-3535-0652~3

FAX : +81-3-3535-0660

OSAKA BRANCH : Higashi Hankyu Bldg. Kakuta-cho 1-1,
Kita-ku Osaka, Japan ZIP CODE 530-0017

TEL : +81-6-6313-1301

FAX : +81-6-6313-0165

NAGOYA BRANCH : Toyo Bldg. 14-16, Meieki 3-chome
Nakamura-ku Nagoya, Japan ZIP CODE 450-0002

TEL : +81-52-541-1141

FAX : +81-52-586-4457

Contents of this manual are subject to change without notice.

QG18744

2011-1 issued