

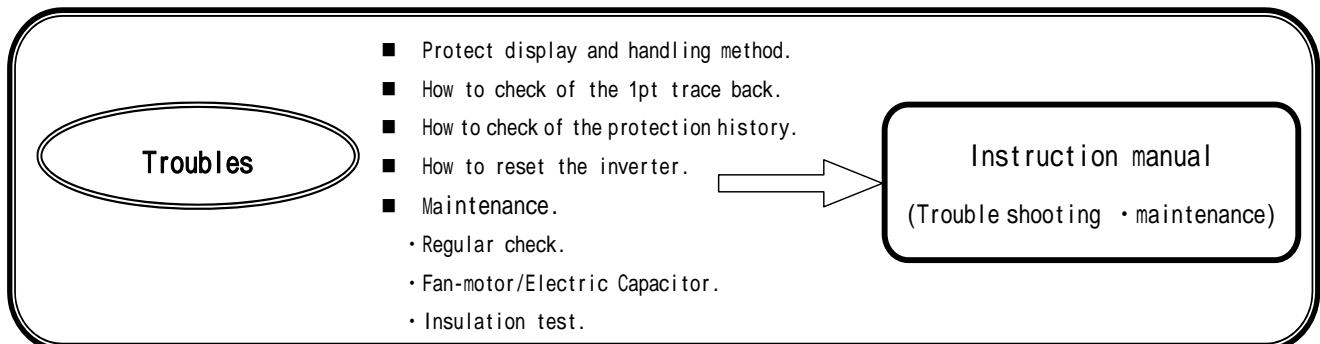

# Foreword

Thank you for purchasing our TOYO VF66B inverter. The manual of VF66B are published in six editions. A simple guide is shown in the following. Please refer to each manual by using severally due to the purpose.

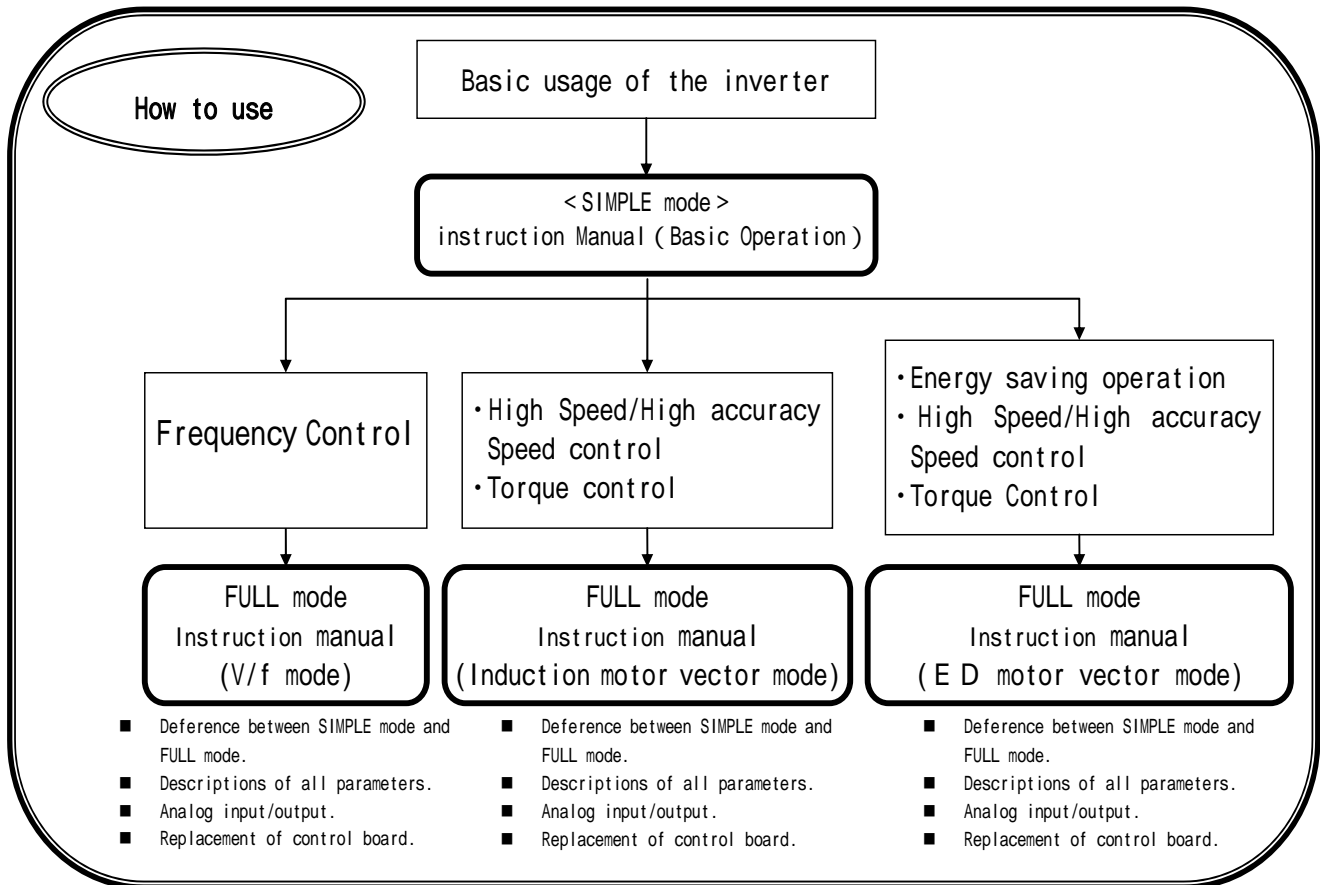
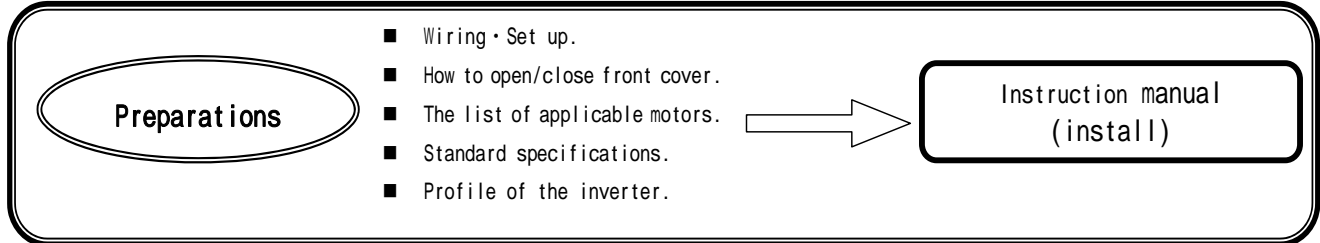

List of protect operation is shown in the following table.

<All unit commonness >

No	Protect display	Protect content	Description of protect operation
1	88888	Communication time error	It operates when it becomes communication time error between VFC66-Z printed board and console panel (SET66-Z).
2	88888	Abnormal stored memory	It operates when it can not obtain correctly setting data stored in built-in memory.
3	88888	Abnormal current sensor	It operates when current sensor is failed.
4	88888	Lacking phase	It operates when output line is broken.
5	88888	External failure1	It operates when external failure 1 of multifunctional input is entered. <sup>(Note)</sup>
6	88888	External failure2	It operates when external failure 2 of multifunctional input is entered. <sup>(Note)</sup>
7	88888	External failure3	It operates when external failure 3 of multifunctional input is entered. <sup>(Note)</sup>
8	88888	External failure4	It operates when external failure 4 of multifunctional input is entered. <sup>(Note)</sup>
9	88888	Input contact of emergency stop A is ON	It operates when multifunctional input set in emergency A turns ON.
10	88888	Input contact of emergency stop B is OFF	It operates when multifunctional input set in emergency stop B turns OFF.
11	88888	FCL operation	It operates when instantaneous current limit continues for 10seconds (2 seconds in the vicinity of 0Hz) sequentially.
12	88888	Fan failure	It operates when fan is failed within the inverter.(No protect stop)
13	88888	IGBT protect operation	It operates when IGBT is over current and gate power source goes down.
14	88888	Overheat motor	It operates when motor temperature exceeds 150 when motor overheat selection setting(F-06) is ON in using temperature detection option. <sup>(Note)</sup>
15	88888	Overcurrent protect	It operates when instantaneous value of output current is 3.58times or more than inverter rated current value.
16	88888	Overfrequency protect	It operates when output frequency exceeds overfrequency setting. (V/f mode)
17	88888	Overheat unit	It operates when temperature of IGBT becomes predetermined value or more.
18	88888	Overload protect	It operates when output current effective value exceeds 150% of motor rated current value for 1 minute.
19	88888	Option error	It operates when the operation of connected option board is failed when using option board is ON. <sup>(Note)</sup>
20	88888	Overspeed protect	It operates when motor speed exceeds overspeed setting. (Induction motor vector mode and ED motor vector mode)















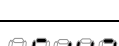
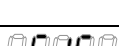

No	Protect display	Protect content	Description of protect operation
21		Over torque protect	It operates when output torque exceeds 150% of rated torque for 1 minute when over torque protect operation setting is ON. (Induction motor vector mode and ED motor vector mode)
22		Overvoltage of DC input voltage.	Model of input 200V : It operates when voltage of DC input voltage exceeds 400V. Model of input 400V: It operates when voltage of DC input voltage exceeds 800V.
23		PG error	<ul style="list-style-type: none"> <li>• It operates when there is no input of U,V,W signal of PG even if it is rotated for 2cycles or more by electric phase.</li> <li>• It operates when there is no input of Z signal of PG even if it is rotated for 2cycles or more by mechanical phase.</li> </ul> (ED motor vector mode)
24		CPU processing glitches	It operates when CPU processing glitches occur due to instantaneous lowering of control 5V and so on. Last digit  shows number in which the error is classified.
25		Overheat charge resistance	It operates when charge resistance is over heat in models of 7.5kW or less.
26		Setting error	It operates when motor operation is started in the abnormal condition of setting motor rating and motor constant. Last two digits  shows number that is classified cause of an abnormal setting.  See "Chapter2 2.1.3 Display content for setting error()" for details.
27		Sensorless starting error	It operates when phase detection at starting is failed in sensorless mode. (ED motor vector mode)
28		Sensor error	It operates when there is no input of current sensor and PG. (ED motor vector mode)
29		Speed control error	It operates when deviation between motor speed and command value (speed control input) exceeds setting value (console setting) when detection of abnormal speed control is ON. (Induction motor vector mode and ED motor vector mode)
30		Start jam	It operates when it is unable to be operated even if it goes by 10 seconds from the time that operation or inching command is input.
31		Communication time out error	Communication error (time out) occurs between option and master when option to communicate across a network is used.
32		Undervoltage (Blackout)	Models of 200V input : It operates when DC voltage becomes 180V or less during operation. Models of 400V input : It operates when DC voltage becomes 360V or less during operation.





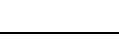
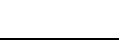



For (Note), see each detailed mode instruction manual and option instruction manual.





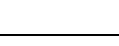

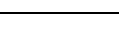

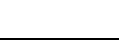
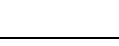
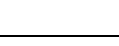
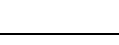
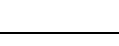
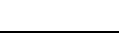
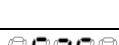
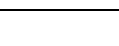

In addition to above mentioned protection, over 30kW unit(over 3022 or 3044) and the parallel model(15022, 18022, 40044~100044) has the protection display function as follows table. The protection displays of unit 30kW~315kW as unity unit are similar to master unit's one in as follows table.

<Only over 30kW unit (the unit over 3022 or over 3044) >

No	Protect Display	Protect content	Description of protect operation
33		Gate amp board error	It is operated when protection relay with up to protection No89 from No34 (except 45,58,72,86).
34		Gate amp board communication error(Master)	It is operated when communication error occurs between master gate amp board and VFC.
35		Gate amp board Power source error (Master)	It is operated when trouble of gate power source occurs in master unit.
36		IGBT protection (phase U ) (Master unit)	It is operated when overcurrent flows to IGBT in phase U in master unit.
37		IGBT protection (phase V ) (Master unit)	It is operated when overcurrent flows to IGBT in phase V in master unit.
38		IGBT protection (phase W ) (Master unit)	It is operated when overcurrent flows to IGBT in phase W in master unit.
39		Over Heat unit (phase U) (Master unit)	It is operated when the temperature of cooling fin of IGBT in U phase in master unit is more than predetermined value.
40		Over Heat unit (phase V) (Master unit)	It is operated when the temperature of cooling fin of IGBT in V phase in master unit is more than predetermined value.
41		Over Heat unit (phase W) (Master unit)	It is operated when the temperature of cooling fin of IGBT in W phase in master unit is more than predetermined value.
42		Fuse blowout (Master unit)	(It is operated only over 75kW unit) It is operated when fuse of main power circuit blows out.
43		FCL operation (Master unit)	It is operated when the current which over 290% of inverter rated current, is flowed over 2sec in all of inverter units.
44		Power source trouble (Master)	It is operated when power source trouble occurs at control board of slave unit in parallelmodel.
45		Fan unit trouble (Master)	(It is operated only over 75kW unit) It is operated when main cooling fan in master unit has trouble. (The inverter does not stop)
46		MC response error (Master)	(It is operated only over 75kW unit) It is operated when the MC of master unit does not ON.
47		Over heat of converter unit (Master)	It is operated when the temperature of cooling fin of the converter of master unit is more than predetermined value.
48		Gate amp board communication error (slave unit1)	It is operated when communication error occurs between slave unit1 and VFC.
49		Gate amp board Power source error (slave unit1)	It is operated when trouble of gate power source occurs in slave unit1.

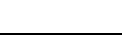
No	Protect Display	Protect content	Description of protect operation
50		IGBT protection (phase U ) (slave unit1)	It is operated when overcurrent flows to IGBT in phase U in slave unit1.
51		IGBT protection (phase V ) (slave unit1)	It is operated when overcurrent flows to IGBT in phase V in slave unit1.
52		IGBT protection (phase W ) (slave unit1)	It is operated when overcurrent flows to IGBT in phase W in slave unit1.
53		Over voltage in DC. (slave unit1)	It is operated when overvoltage occurs in DC link in slave unit1. 200V class unit : It operates over 400V in DC part. 400V class unit : It operates over 800V in DC part.
54		Over Heat unit (phase U) (slave unit1)	It is operated when the temperature of cooling fin of IGBT in U phase in slave unit1 is more than predetermined value.
55		Over Heat unit (phase V) (slave unit1)	It is operated when the temperature of cooling fin of IGBT in V phase in slave unit1 is more than predetermined value.
56		Over Heat unit (phase W) (slave unit1)	It is operated when the temperature of cooling fin of IGBT in W phase in slave unit1 is more than predetermined value.
57		Fuse blowout (slave unit1)	It is operated when fuse of main power circuit blows out in slave unit1.
58		Fan unit trouble (slave unit1)	It is operated when main cooling fan in slave unit1 has trouble. (The inverter does not stop)
59		Control source trouble (slave unit1)	It is operated when control source of slave unit1 drops down.
60		MC response error (slave unit1)	It is operated when the MC of slave unit1 does not ON.
61		Over heat of converter unit (slave unit1)	It is operated when the temperature of cooling fin of the converter of slave unit1 is more than predetermined value.
62		Gate amp board communication error (slave unit2)	It is operated when communication error occurs between slave unit2 and VFC.
63		Gate amp board Power source error (slave unit2)	It is operated when trouble of gate power source occurs in slave unit2.
64		IGBT protection (phase U ) (slave unit2)	It is operated when overcurrent flows to IGBT in phase U in slave unit2.
65		IGBT protection (phase V ) (slave unit2)	It is operated when overcurrent flows to IGBT in phase V in slave unit2.
66		IGBT protection (phase W ) (slave unit2)	It is operated when overcurrent flows to IGBT in phase W in slave unit2.
67		Over voltage in DC. (slave unit2)	It is operated when overvoltage occurs in DC link in slave unit2. 200V class unit : It operates over 400V in DC part. 400V class unit : It operates over 800V in DC part.

No	Protect Display	Protect content	Description of protect operation
68		Over Heat unit (phase U) (slave unit2)	It is operated when the temperature of cooling fin of IGBT in U phase in slave unit2 is more than predetermined value.
69		Over Heat unit (phase V) (slave unit2)	It is operated when the temperature of cooling fin of IGBT in V phase in slave unit2 is more than predetermined value.
70		Over Heat unit (phase W) (slave unit2)	It is operated when the temperature of cooling fin of IGBT in W phase in slave unit2 is more than predetermined value.
71		Fuse blowout (slave unit2)	It is operated when fuse of main power circuit blows out in slave unit2.
72		Fan unit trouble (slave unit2)	It is operated when main cooling fan in slave unit2 has trouble. (The inverter does not stop)
73		Control source trouble (slave unit2)	It is operated when control source of slave unit2 drops down.
74		MC response error (slave unit2)	It is operated when the MC of slave unit2 does not ON.
75		Over heat of converter unit (slave unit2)	It is operated when the temperature of cooling fin of the converter of slave unit2 is more than predetermined value.
76		Gate amp board communication error (slave unit3)	It is operated when communication error occurs between slave unit3 and VFC.
77		Gate amp board Power source error (slave unit3)	It is operated when trouble of gate power source occurs in slave unit3.
78		IGBT protection (phase U ) (slave unit3)	It is operated when overcurrent flows to IGBT in phase U in slave unit3.
79		IGBT protection (phase V ) (slave unit3)	It is operated when overcurrent flows to IGBT in phase V in slave unit3.
80		IGBT protection (phase W ) (slave unit3)	It is operated when overcurrent flows to IGBT in phase W in slave unit3.
81		Over voltage in DC. (slave unit3)	It is operated when overvoltage occurs in DC link in slave unit3. 200V class unit : It operates over 400V in DC part. 400V class unit : It operates over 800V in DC part.
82		Over Heat unit (phase U) (slave unit3)	It is operated when the temperature of cooling fin of IGBT in U phase in slave unit3 is more than predetermined value.
83		Over Heat unit (phase V) (slave unit3)	It is operated when the temperature of cooling fin of IGBT in V phase in slave unit3 is more than predetermined value.
84		Over Heat unit (phase W) (slave unit3)	It is operated when the temperature of cooling fin of IGBT in W phase in slave unit3 is more than predetermined value.
85		Fuse blowout (slave unit3)	It is operated when fuse of main power circuit blows out in slave unit3.

No	Protect Display	Protect content	Description of protect operation
86		Fan unit trouble (slave unit3)	It is operated when main cooling fan in slave unit3 has trouble. (The inverter does not stop)
87		Control source trouble (slave unit3)	It is operated when control source of slave unit3 drops down.
88		MC response error (slave unit3)	It is operated when the MC of slave unit3 does not ON.
89		Over heat of converter unit (slave unit3)	It is operated when the temperature of cooling fin of the converter of slave unit3 is more than predetermined value.
90		VFDB1(Regeneration braking unit1) error	It is operated when VFDB1(Regeneration braking unit 1) is protected or it has communication error. (The inverter does not stop)
91		VFDB2(Regeneration braking unit2) error	It is operated when VFDB2(Regeneration braking unit 2) is protected or it has communication error. (The inverter does not stop)
92		VFDB3(Regeneration braking unit3) error	It is operated when VFDB3(Regeneration braking unit 3) is protected or it has communication error. (The inverter does not stop)
93		VFDB4(Regeneration braking unit4) error	It is operated when VFDB4(Regeneration braking unit 4) is protected or it has communication error. (The inverter does not stop)
94		VFDB5(Regeneration braking unit5) error	It is operated when VFDB5(Regeneration braking unit 5) is protected or it has communication error. (The inverter does not stop)
95		VFDB6(Regeneration braking unit6) error	It is operated when VFDB6(Regeneration braking unit 6) is protected or it has communication error. (The inverter does not stop)

# **TOYODENKI SEIZO K.K.**

<http://www.toyodenki.co.jp/>

HAED OFFICE: No.1 Nurihiko Bldg. 9-2 Kyobashi 2-chome Chuo-ku,  
Tokyo, Japan ZIP CODE 104-0031

TEL : +81-3-3535-0652 ~ 3

FAX : +81-3-3535-0660

OSAKA BRANCH : Higashi Hankyu Bldg. Kakuta-cho 1-1,  
Kita-ku Osaka, Japan ZIP CODE 530-0017

TEL : +81-6-6313-1301

FAX : +81-6-6313-0165

NAGOYA BRANCH : Toyo Bldg., 14-16, Meieki 3-chome  
Nakamura-ku, Nagoya, Japan. ZIP CODE 450-0002

TEL : +81-52-541-1141

FAX : +81-52-586-4457

Contents of this manual are subject to change without notice.

QG18538

2009-10