

Foreword

Thank you for purchasing our TOYO VF66B inverter.

This instruction manual is designed to introduce the option to upgrade functions of TOYO VF66B inverter.

For installing, wiring, and operating inverter see each option instruction manuals.

Contents

Selection of peripheral device and option.....	3
1.1. Selection guide	3
1.2. DC Reactor.....	4
1.3. AC Reactor.....	5
1.4. Noise filter.....	7
1.5. Sine wave converter.....	9
1.6. Regeneration braking unit	9
Contact us	10

Selection of peripheral device and option

1.1. Selection guide

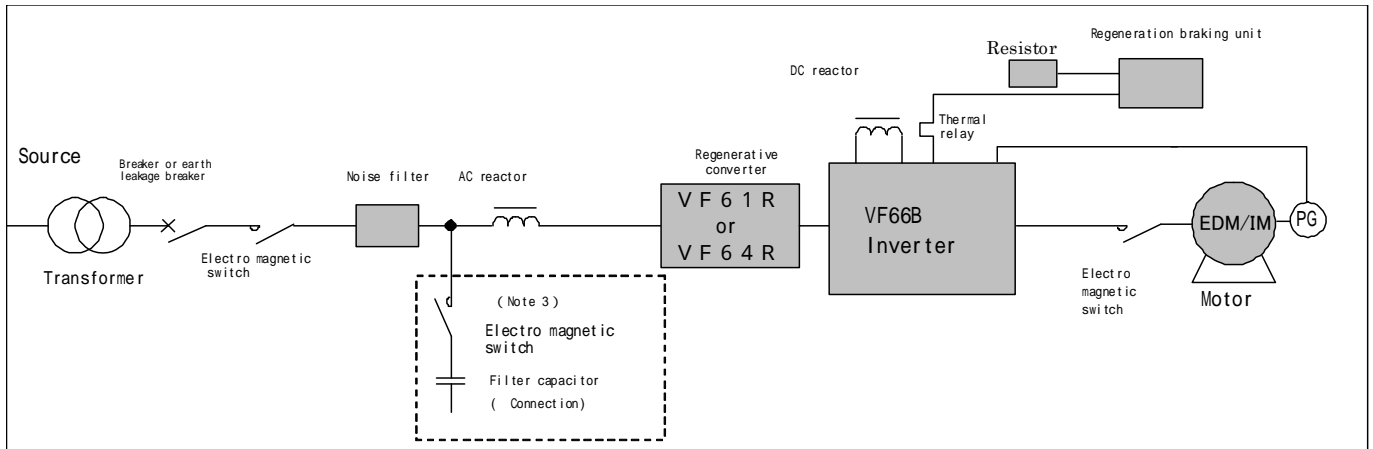

	Name	Type	Application	Remarks
D e v i c e	DC Reactor	DCL	When you want to improve input power factor, please install this device.	Connect between $\oplus 1 \sim \oplus 2$
	AC Reactor	AL	When you want to improve input power factor and current distortion, please install this device.	For connection on input side
	Noise filter	NF3	When you want to reduce electromagnetic noise generated from the inverter, please apply this device. NF3 is noise filter for damping high bandwidth.	For connection on input side
	Sine wave converter	VF61R or VF64R	Install this, if it is necessary for the large improvement of power source regenerative braking and power source harmonic and input power factor. It is necessary to install ACL for converter if sine wave converter is installed. See the brochure and instruction manual of VF61R (VF64R) for various capacities.	Apply on inverter input side
	Regeneration braking unit Resistor Thermal relay	VFDB R TH-	Install this, if it is necessary for braking effort of motor. Use in combination of Regeneration braking unit, resistor and thermal relay when it is applied. (Regeneration braking unit of the models up to 22kW is built-in the inverter.)	Connect between $\oplus 2$ and \ominus . The models which regeneration braking unit is built in, connect resistor and thermal relay between B and $\oplus 2$.

(Note1) Select circuit breaker, input side and output side electromagnetic connector, and wiring size in consideration of capacity, power factor and current.

(Note2) Use earth leakage breaker corresponding to inverter.

(Note3) Filter capacitor and electromagnetic contactor for its input is required when sine wave converter(VF61R or VF64R) is used. Electromagnetic contactor for input is used in the way that it turns ON when sine wave converter is operated and it turns OFF when sine wave converter stops.

(Note4) Use input side and output side electromagnetic contactor depending on the intended use. Since permanent magnet is built-in ED motor, voltage is generated even if inverter stops when the motor is rotated. We recommend that you use the electromagnetic contactor on output side for the safe if you use constant output (power constant) area and motor may be rotated by other power. In this case, you bring output side electromagnetic contactor to operate at operating contact point of inverter(52MA).

1.2. DC Reactor

You can apply DC reactor as option if you want to improve input power factor. Use the following reactor.

Outline and dimension

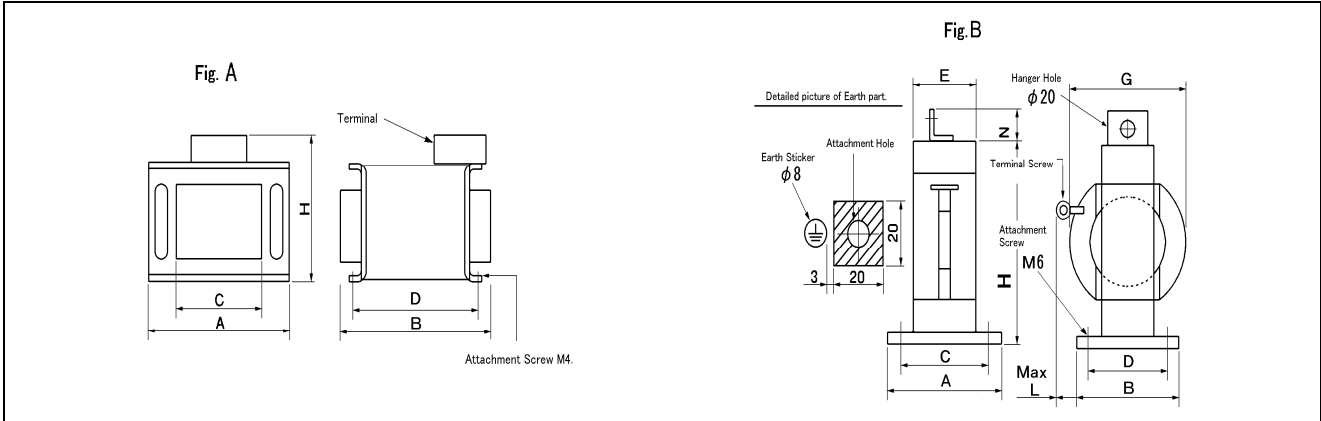

200V class

Inverter capacity	DC reactor type	Dimension (mm)										Fig.	Mass (kg)
		A	B	C	D	E	G	H	N	L	Terminal		
VF66B-2R222	DCL3R722	97	90	70	55	-	-	120	-	-	M4	A	2.1
VF66B-3R722	DCL3R722	97	90	70	55	-	-	120	-	-	M4		2.1
VF66B-5R522	DCL7R522	97	100	70	75	-	-	130	-	-	M6		3.3
VF66B-7R522	DCL7R522	97	100	70	75	-	-	130	-	-	M6		3.3
VF66B-1122	DCL1122	60	110	40	90	48	181	205	-	110	M6	B	4.0
VF66B-1522	DCL1522	60	110	40	90	48	169	212	-	110	M8		5.0
VF66B-2222	DCL2222	60	110	40	90	50	189	226	-	110	M10		6.0
VF66B-3022	DCL3022	90	120	70	100	75	181	224	-	90	M10		10
VF66B-3722	DCL3722	90	120	70	100	77	182	226	-	90	M10		10
VF66B-4522	DCL4522	110	125	90	105	81	170	214	-	90	M12		11
VF66B-5522	DCL5522	120	145	100	125	107	182	236	-	90	M12	15	

400V class

Inverter capacity	DC reactor type	Dimension (mm)										Fig.	Mass (kg)
		A	B	C	D	E	G	H	N	L	Terminal		
VF66B-2R244	DCL3R744	78	80	55	62	-	-	100	-	-	M3	A	1.6
VF66B-3R744	DCL3R744	78	80	55	62	-	-	100	-	-	M3		1.6
VF66B-5R544	DCL7R544	97	100	70	70	-	-	120	-	-	M4		3.1
VF66B-7R544	DCL7R544	97	100	70	70	-	-	120	-	-	M4		3.1
VF66B-1144	DCL1544	106	100	80	75	-	-	150	-	-	M6	B	4.0
VF66B-1544	DCL1544	106	100	80	75	-	-	150	-	-	M6		4.0
VF66B-2244	DCL2244	60	120	40	100	47	210	254	-	110	M6		6.0
VF66B-3044	DCL3044	60	120	40	100	48	192	235	-	90	M6		6.5
VF66B-3744	DCL3744	90	120	70	100	75	195	238	-	90	M8		10
VF66B-4544	DCL4544	90	120	70	100	75	186	230	-	90	M10		10
VF66B-5544	DCL5544	110	125	90	105	90	194	248	-	90	M10	14	

⚠ Caution

[Caution for mounting]

Since DC reactor becomes hot, do not locate the device affected by heat near DC reactor. In addition, do not circulate heat of DC reactor within the board.

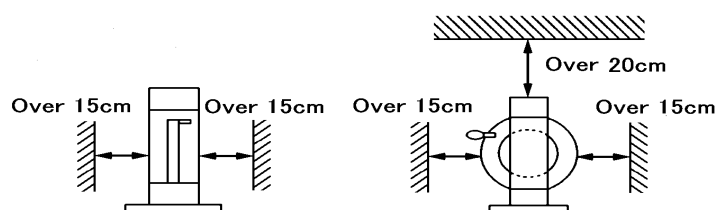

1.3. AC Reactor

You can apply AC reactor as option if you want to improve input power factor and distortion property. Use the followings of inverter input side AC reactor.

200V class	
Inverter type	AC reactor type
VF66B-2R222	AL15A1000L
VF66B-3R722	AL20A333L
VF66B-5R522	AL37A180L
VF66B-7R522	AL55A122L
VF66B-1122	AL70A97L
VF66B-1522	AL84A80L
VF66B-2222	AL140A49L
VF66B-3022	AL173A39L
VF66B-3722	AL209A32L
VF66B-4522	AL253A27L
VF66B-5522	AL270A26L
VF66B-7522	AL341A20L
VF66B-9022	AL416A17L
VF66B-15022	AL341A20L×2
VF66B-18022	AL416A17L×2

400V class	
Inverter type	AC reactor type
VF66B-2R244	AL15A1000L
VF66B-3R744	AL15A1000L
VF66B-5R544	AL20A333L
VF66B-7R544	AL28A237L
VF66B-1144	AL37A180L
VF66B-1544	AL55A122L
VF66B-2244	AL70A97L
VF66B-3044	AL84A80L
VF66B-3744	AL105A64L
VF66B-4544	AL140A49L
VF66B-5544	AL173A39L
VF66B-7544	AL173A39L
VF66B-11044	AL253A27L
VF66B-16044	AL416A17L
VF66B-20044	AL503A14L
VF66B-25044	AL585A11L
VF66B-31544	AL850A8L
VF66B-40044	AL503A14L×2
VF66B-50044	AL585A11L×2
VF66B-60044	AL503A14L×3
VF66B-75044	AL585A11L×3
VF66B-100044	AL585A11L×4

Outline and dimension

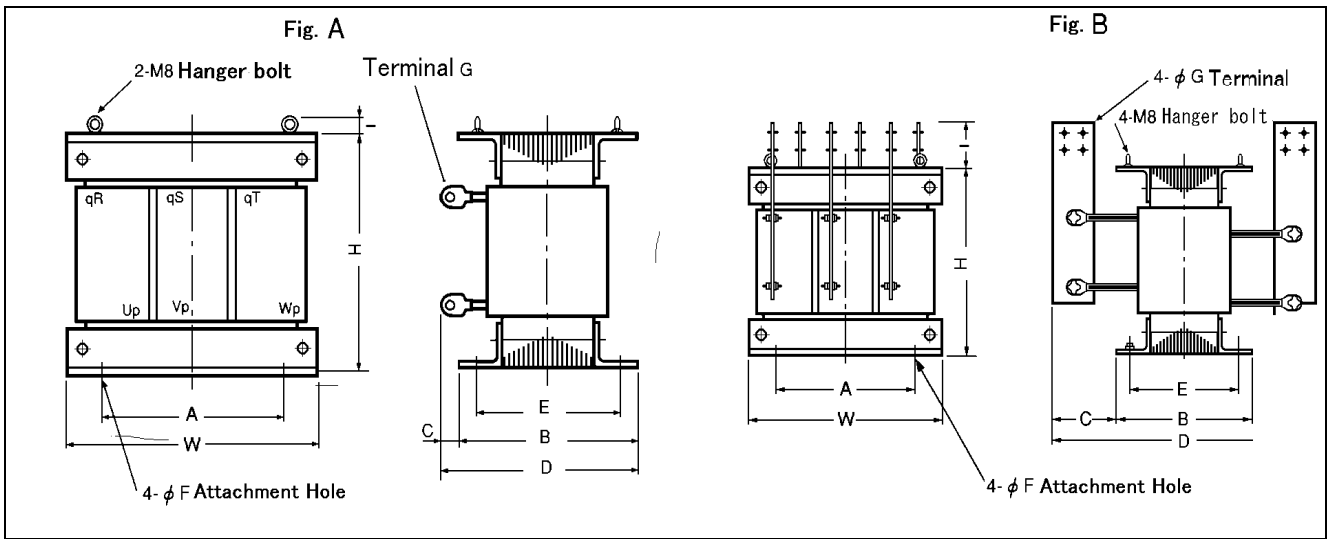

Type	W	H	D	A	B	C	E	F	G	I	Fig.	Mass
AL15A1000L	150	117	118	90	78	40	58	7	M4	-	A	4.3
AL20A333L	160	110	120	100	80	40	60	7	M8	-		3.4
AL37A180L	170	120	123	100	83	40	70	7	M6	-		3.9
AL55A122L	170	130	135	100	95	40	70	7	M8	-		4.2
AL70A97L	170	115	133	100	92	40	75	7	M8	-		4.9
AL84A80L	170	115	142	100	102	40	75	7	M8	-		5.4
AL105A64L	190	140	155	100	105	50	75	7	M10	-		7.5
AL140A49L	190	155	155	100	105	50	75	7	M10	-		9.0
AL173A39L	190	155	158	100	108	50	80	7	M10	-		10
AL209A32L	220	185	173	150	113	60	90	7	M10	-		14
AL253A27L	250	210	188	160	138	50	100	7	M12	-		19
AL270A26L	240	195	220	150	120	100	95	9	M12	-		19
AL341A20L	220	190	191	150	121	70	90	7	M12	-		15
AL416A17L	280	235	230	150	160	70	120	10	M12	40		28
AL503A14L	300	265	240	150	170	70	130	10	M16	40	32	
AL585A11L	300	255	280	180	150	130	112	10	M12	35	45	
AL850A8L	350	345	342	250	172	170	122	15	M14	90	B	75

1.4. Noise filter

Noise filter can be applied if you want to reduce electromagnetic noise generated from inverter. Use the followings of noise filter.

200V class	
Inverter type	Noise filter type
VF66B-2R222	NF3015A-CD
VF66B-3R722	NF3020A-CD
VF66B-5R522	NF3030A-CD
VF66B-7R522	NF3040A-CD
VF66B-1122	NF3060A-CD
VF66B-1522	NF3080A-CD
VF66B-2222	NF3150A-CD
VF66B-3022	NF3150A-CD
VF66B-3722	NF3150A-CD
VF66B-4522	NF3200A-CD
VF66B-5522	NF3250A-CD
VF66B-7522	NF3400A-CD
VF66B-9022	NF3400A-CD
VF66B-15022	NF3400A-CD × 2 (Note1)
VF66B-18022	NF3400A-CD × 2 (Note1)

400V class	
Inverter type	Noise filter type
VF66B-2R244	NF3010C-CD
VF66B-3R744	NF3015C-CD
VF66B-5R544	NF3020C-CD
VF66B-7R544	NF3030C-CD
VF66B-1144	NF3030C-CD
VF66B-1544	NF3040C-CD
VF66B-2244	NF3060C-CD
VF66B-3044	NF3080C-CD
VF66B-3744	NF3080C-CD
VF66B-4544	NF3100C-CD
VF66B-5544	NF3150C-CD
VF66B-7544	NF3200C-CD
VF66B-11044	NF3250C-CD
VF66B-16044	NF3400C-CD
VF66B-20044	NF3500C-CD
VF66B-25044	NF3600C-CD
VF66B-31544	NF31000C-CD
VF66B-40044	NF31000C-CD (Note1)
VF66B-50044	NF31000C-CD (Note1)
VF66B-60044	NF31000C-CD × 3 (Note1)
VF66B-75044	NF31000C-CD × 3 (Note1)
VF66B-100044	NF31000C-CD × 3 (Note1)

(Note1) You have to install noise filter to each Master inverter and Slave inverter respectively.

Outline and dimension

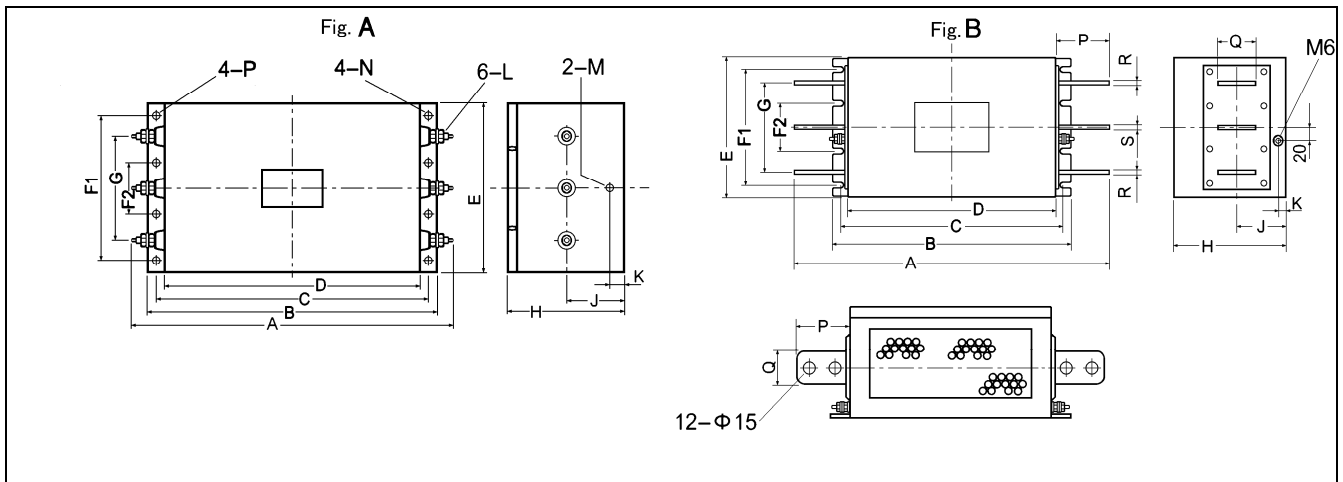

Type		Dimension(Unit mm)																		
200V class	400V class	A	B	C	D	E	F1	F2	G	H	J	K	L	M	N	P	Q	R	S	Fig
NF3015A-CD	NF3010C-CD	167	160	145	130	110	80	-	60	70	35	15	-	-	φ5.5	R2.75x7	-	-	-	A
NF3020A-CD	NF3015C-CD																			
-	NF3020C-CD																			
NF3030A-CD	-	175	160	145	130	110	80	-	60	70	35	15	M4	M5	φ5.5	R2.75x7	-	-	-	A
NF3040A-CD	NF3030C-CD	215	200	185	170	120	90	-	70	70	35	15	M4	M5	φ5.5	R2.75x7	-	-	-	A
-	NF3040C-CD																			
NF3060A-CD	NF3060C-CD	255	230	215	200	140	110	-	80	80	40	15	M4	M5	φ6.5	R2.75x8	-	-	-	A
NF3080A-CD	-	310	280	260	240	200	150	-	120	100	55	20	M6	M8	φ6.5	R2.75x8	-	-	-	A
NF3150A-CD	-	435	370	350	330	210	170	60	120	155	95	20	M12	M6	φ6.5	R3.25x8	-	-	-	A
NF3080A-CD	NF3080C-CD	310	280	260	240	200	150	-	120	100	55	20	M6	M8	φ6.5	R2.75x8	-	-	-	A
-	NF3100C-CD	420	370	350	330	210	170	60	120	155	95	20	M10	M6	φ6.5	R3.25x8	-	-	-	A
NF3150A-CD	NF3150C-CD	435	370	350	330	210	170	60	120	155	95	20	M12	M6	φ6.5	R3.25x8	-	-	-	A
NF3200A-CD	NF3200C-CD	475	410	390	370	230	190	70	140	180	100	25	M12	M6	φ6.5	R3.25x8	-	-	-	A
NF3250A-CD	NF3250C-CD	475	410	390	370	230	190	70	140	180	100	25	M12	M6	φ6.5	R3.25x8	-	-	-	A
NF3400A-CD	-	450	340	310	280	220	180	80	146	170	85	18	-	-	-	80	45	4.5	4	B
-	NF3400C-CD	485	375	345	315	220	180	80	146	170	85	18	-	-	-	80	45	4.5	4	B
-	NF3400C-CD	485	375	345	315	220	180	80	146	170	85	18	-	-	-	80	45	4.5	4	B
-	NF3500C-CD	595	445	415	385	240	200	80	160	170	85	18	-	-	-	95	60	5	4.5	B
-	NF3600C-CD	595	445	415	385	240	200	80	160	170	85	18	-	-	-	95	60	7	6	B

1.5. Sine wave converter

If you want to regenerate energy at brake torque into power source and improve input power factor and distortion property, you can use sine wave converter to be able to regenerate electric power. We have VF61R or VF46R series as sine wave converter unit. Please make inquiries about details for our sales or see additional volumes of “VF61R sine wave converter instruction manual” and “VF64R PWM sine wave converter instruction manual” for details.

1.6. Regeneration braking unit

When sine wave converter is not used if brake torque is required, use regeneration braking unit (DB unit) to handle energy generated. Transistor for regeneration braking is built-in VF66B and VF66B can perform regeneration braking by adding resistance and protection relay outside. Please make inquiries about details for our sales or see additional volume of DB unit “Instruction manual” for details.

Contact us

Please inform us or the distributor of the following information when you have order for replacement parts or technical questions.

- 1) Inverter type, capacity (kW) and input voltage(V)
- 2) Motor type, capacity (kW), rated rotation speed(r/min), motor rated voltage, and motor pole number
- 3) Serial number and software version number(Check the label on the following control printed board VFC66-Z for software version number.)

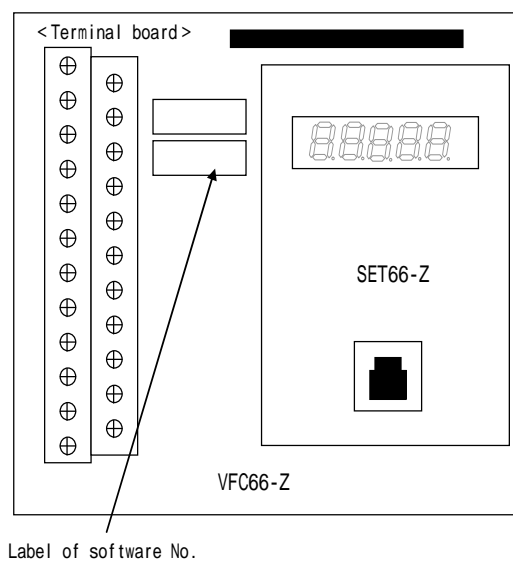

- 4) Details of failure and condition at failure
- 5) Working condition, load condition, ambient condition, date of purchase, and operation condition
- 6) Name of agent and sales

To distributors

When you deliver your product incorporating this inverter, ensure the end user receives this manual. When the adjusted values of this inverter are changed from the setting value, ensure the end user knows the changes.

TOYODENKI SEIZO K.K.

<http://www.toyodenki.co.jp/>

HAED OFFICE: No.1 Nurihiko Bldg. 9-2 Kyobashi 2-chome Chuo-ku,
Tokyo, Japan ZIP CODE 104-0031

TEL : +81-3-3535-0652 ~ 3

FAX : +81-3-3535-0660

OSAKA BRANCH : Higashi Hankyu Bldg. Kakuta-cho 1-1,
Kita-ku Osaka, Japan ZIP CODE 530-0017

TEL : +81-6-6313-1301

FAX : +81-6-6313-0165

NAGOYA BRANCH : Toyo Bldg., 14-16, Meieki 3-chome
Nakamura-ku, Nagoya, Japan. ZIP CODE 450-0002

TEL : +81-52-541-1141

FAX : +81-52-586-4457

Contents of this manual are subject to change without notice.

QG18537

2009-10